

SECTION **EXT**  
EXTERIOR

A  
B  
C  
D  
E  
F  
G  
H  
I  
J  
L  
M  
N  
O  
P

CONTENTS

<b>SYMPTOM DIAGNOSIS</b> .....	3	Removal and Installation .....	21
<b>SQUEAK AND RATTLE TROUBLE DIAG- NOSES</b> .....	3	<b>FENDER PROTECTOR</b> .....	24
Work Flow .....	3	<b>FENDER PROTECTOR</b> .....	24
Inspection Procedure .....	5	FENDER PROTECTOR : Exploded View .....	24
Diagnostic Worksheet .....	7	FENDER PROTECTOR : Removal and Installa- tion .....	24
<b>PRECAUTION</b> .....	9	<b>REAR WHEEL HOUSE PROTECTOR</b> .....	25
<b>PRECAUTIONS</b> .....	9	REAR WHEEL HOUSE PROTECTOR : Exploded View .....	25
Precaution for Supplemental Restraint System (SRS) "AIR BAG" and "SEAT BELT PRE-TEN- SIONER" .....	9	REAR WHEEL HOUSE PROTECTOR : Removal and Installation .....	25
Precaution Necessary for Steering Wheel Rota- tion after Battery Disconnect .....	9	<b>CENTER MUD GUARD</b> .....	27
Precaution for Battery Service .....	10	Exploded View .....	27
Precaution for Procedure without Cowl Top Cover... ..	10	Removal and Installation .....	27
Precaution for Work .....	10	<b>FLOOR SIDE FAIRING</b> .....	29
<b>PREPARATION</b> .....	11	Exploded View .....	29
<b>PREPARATION</b> .....	11	Removal and Installation .....	29
Special Service Tools .....	11	<b>ROOF SIDE MOLDING</b> .....	31
Commercial Service Tools .....	11	Exploded View .....	31
<b>REMOVAL AND INSTALLATION</b> .....	12	Removal and Installation .....	31
<b>FRONT BUMPER</b> .....	12	<b>FRONT PILLAR FINISHER</b> .....	33
Exploded View .....	12	Exploded View .....	33
Removal and Installation .....	13	Removal and Installation .....	33
<b>REAR BUMPER</b> .....	16	<b>DOOR OUTSIDE MOLDING</b> .....	35
Exploded View .....	16	Exploded View .....	35
Removal and Installation .....	17	Removal and Installation .....	35
<b>FRONT GRILLE</b> .....	19	<b>DOOR PARTING SEAL</b> .....	36
Exploded View .....	19	Exploded View .....	36
Removal and Installation .....	19	Removal and Installation .....	36
<b>COWL TOP</b> .....	21	<b>TRUNK LID FINISHER</b> .....	37
Exploded View .....	21	<b>TRUNK LID OUTER FINISHER</b> .....	37
		TRUNK LID OUTER FINISHER : Exploded View... ..	37

EXT

---

TRUNK LID OUTER FINISHER : Removal and Installation .....	37	TRUNK DRIP COVER : Removal and Installation...	39
<b>TRUNK DRIP COVER .....</b>	<b>38</b>	<b>REAR SPOILER .....</b>	<b>41</b>
TRUNK DRIP COVER : Exploded View .....	39	Exploded View .....	41
		Removal and Installation .....	41

# SQUEAK AND RATTLE TROUBLE DIAGNOSES

< SYMPTOM DIAGNOSIS >

## SYMPTOM DIAGNOSIS

### SQUEAK AND RATTLE TROUBLE DIAGNOSES

#### Work Flow

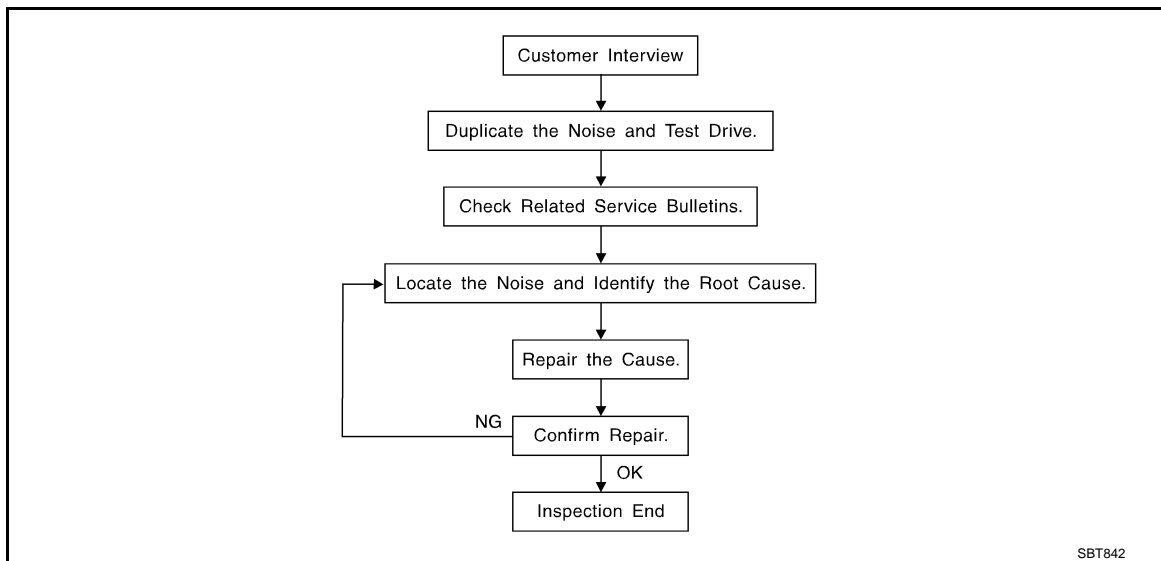

#### CUSTOMER INTERVIEW

Interview the customer if possible, to determine the conditions that exist when the noise occurs. Use the Diagnostic Worksheet during the interview to document the facts and conditions when the noise occurs and any of customer's comments; refer to [EXT-7, "Diagnostic Worksheet"](#). This information is necessary to duplicate the conditions that exist when the noise occurs.

- The customer may not be able to provide a detailed description or the location of the noise. Attempt to obtain all the facts and conditions that exist when the noise occurs (or does not occur).
- If there is more than one noise in the vehicle, perform a diagnosis and repair the noise that the customer is concerned about. This can be accomplished by performing a cruise test on the vehicle with the customer.
- After identifying the type of noise, isolate the noise in terms of its characteristics. The noise characteristics are provided so the customer, service adviser and technician are all speaking the same language when defining the noise.
- Squeak – (Like tennis shoes on a clean floor)  
Squeak characteristics include the light contact/fast movement/brought on by road conditions/hard surfaces = higher pitch noise/softer surfaces = lower pitch noises/edge to surface = chirping
- Creak – (Like walking on an old wooden floor)  
Creak characteristics include firm contact/slow movement/twisting with a rotational movement/pitch dependent on materials/often brought on by activity.
- Rattle – (Like shaking a baby rattle)  
Rattle characteristics include the fast repeated contact/vibration or similar movement/loose parts/missing clip or fastener/incorrect clearance.
- Knock – (Like a knock on a door)  
Knock characteristics include hollow sounding/sometimes repeating/often brought on by driver action.
- Tick – (Like a clock second hand)  
Tick characteristics include gentle contacting of light materials/loose components/can be caused by driver action or road conditions.
- Thump – (Heavy, muffled knock noise)  
Thump characteristics include softer knock/dead sound often brought on by activity.
- Buzz – (Like a bumblebee)  
Buzz characteristics include high frequency rattle/firm contact.
- Often the degree of acceptable noise level will vary depending up on the person. A noise that a technician may judge as acceptable may be very irritating to the customer.
- Weather conditions, especially humidity and temperature, may have a great effect on noise level.

#### DUPLICATE THE NOISE AND TEST DRIVE

# SQUEAK AND RATTLE TROUBLE DIAGNOSES

## < SYMPTOM DIAGNOSIS >

If possible, drive the vehicle with the customer until the noise is duplicated. Note any additional information on the Diagnostic Worksheet regarding the conditions or location of the noise. This information can be used to duplicate the same conditions when the repair is reconfirmed.

If the noise can be duplicated easily during the test drive, to help identify the source of the noise, try to duplicate the noise with the vehicle stopped by doing one or all of the following:

- 1) Close a door.
  - 2) Tap or push/pull around the area where the noise appears to be coming from.
  - 3) Rev the engine.
  - 4) Use a floor jack to recreate vehicle "twist".
  - 5) At idle, apply engine load (electrical load, half-clutch on M/T models, drive position on A/T models).
  - 6) Raise the vehicle on a hoist and hit a tire with a rubber hammer.
- Drive the vehicle and attempt to duplicate the conditions the customer states exist when the noise occurs.
  - If it is difficult to duplicate the noise, drive the vehicle slowly on an undulating or rough road to stress the vehicle body.

## CHECK RELATED SERVICE BULLETINS

After verifying the customer concern or symptom, check ASIST for Technical Service Bulletins (TSBs) related to that concern or symptom.

If a TSB relates to the symptom, follow the procedure to repair the noise.

## LOCATE THE NOISE AND IDENTIFY THE ROOT CAUSE

1. Narrow down the noise to a general area. To help pinpoint the source of the noise, use a listening tool (Chassis ear: J-39570, Engine ear and mechanics stethoscope).
2. Narrow down the noise to a more specific area and identify the cause of the noise by:
  - Removing the components in the area that is are suspected to be the cause of the noise.  
Do not use too much force when removing clips and fasteners, otherwise clips and fastener can be broken or lost during the repair, resulting in the creation of new noise.
  - Tapping or pushing/pulling the component that is are suspected to be the cause of the noise.  
Do not tap or push/pull the component with excessive force, otherwise the noise will be eliminated only temporarily.
  - Feeling for a vibration by hand by touching the component(s) that is are suspected to be the cause of the noise.
  - Placing a piece of paper between components that are suspected to be the cause of the noise.
  - Looking for loose components and contact marks.  
Refer to [EXT-5. "Inspection Procedure"](#).

## REPAIR THE CAUSE

- If the cause is a loose component, tighten the component securely.
- If the cause is insufficient clearance between components:
  - Separate components by repositioning or loosening and retightening the component, if possible.
  - Insulate components with a suitable insulator such as urethane pads, foam blocks, felt cloth tape or urethane tape. A Nissan Squeak and Rattle Kit (J-43980) is available through the authorized Nissan Parts Department.

### **CAUTION:**

**Never use excessive force as many components are constructed of plastic and may be damaged.**

### **NOTE:**

Always check with the Parts Department for the latest parts information.

The following materials are contained in the Nissan Squeak and Rattle Kit (J-43980). Each item can be ordered separately as needed.

URETHANE PADS [1.5 mm (0.059 in) thick]

Insulates connectors, harness, etc.

- 76268-9E005: 100 × 135 mm (3.937 × 5.315 in)
- 76884-71L01: 60 × 85 mm (2.362 × 3.346 in)
- 76884-71L02: 15 × 25 mm (0.591 × 0.984 in)

INSULATOR (Foam blocks)

Insulates components from contact. Can be used to fill space behind a panel.

- 73982-9E000: 45 mm (1.772 in) thick, 50 × 50 mm (1.969 × 1.969 in)
- 73982-50Y00: 10 mm (0.394 in) thick, 50 × 50 mm (1.969 × 1.969 in)

INSULATOR (Light foam block)

80845-71L00: 30 mm (1.18 in) thick, 30 × 50 mm (1.181 × 1.969in)

FELT CLOTHTAPE

# SQUEAK AND RATTLE TROUBLE DIAGNOSES

## < SYMPTOM DIAGNOSIS >

Used to insulate where movement does not occur. Ideal for instrument panel applications.

- 68370-4B000: 15 × 25 mm (0.591 × 0.984 in) pad
- 68239-13E00: 5 mm (0.197 in) wide tape roll

The following materials, not found in the kit, can also be used to repair squeaks and rattles.

### UHMW (TEFLON) TAPE

Insulates where slight movement is present. Ideal for instrument panel applications.

### SILICONE GREASE

Used in place of UHMW tape that is be visible or does not fit. Will only last a few months.

### SILICONE SPRAY

Used when grease cannot be applied.

### DUCT TAPE

Used to eliminate movement.

## CONFIRM THE REPAIR

Confirm that the cause of a noise is repaired by test driving the vehicle. Operate the vehicle under the same conditions as when the noise originally occurred. Refer to the notes on the Diagnostic Worksheet.

## Inspection Procedure

INFOID:000000004678285

Refer to Table of Contents for specific component removal and installation information.

## INSTRUMENT PANEL

Most incidents are caused by contact and movement between:

1. The cluster lid A and instrument panel
2. Acrylic lens and combination meter housing
3. Instrument panel to front pillar garnish
4. Instrument panel to windshield
5. Instrument panel mounting pins
6. Wiring harnesses behind the combination meter
7. A/C defroster duct and duct joint

These incidents can usually be located by tapping or moving the components to duplicate the noise or by pressing on the components while driving to stop the noise. Most of these incidents can be repaired by applying felt cloth tape or silicon spray (in hard to reach areas). Urethane pads can be used to insulate wiring harness.

### **CAUTION:**

**Never use silicone spray to isolate a squeak or rattle. If the area is saturated with silicone, the recheck of repair becomes impossible.**

## CENTER CONSOLE

Components to pay attention to include:

1. Shifter assembly cover to finisher
2. A/C control unit and cluster lid C
3. Wiring harnesses behind audio and A/C control unit

The instrument panel repair and isolation procedures also apply to the center console.

## DOORS

Pay attention to the following:

1. Finisher and inner panel making a slapping noise
2. Inside handle escutcheon to door finisher
3. Wiring harnesses tapping
4. Door striker out of alignment causing a popping noise on starts and stops

Tapping or moving the components or pressing on them while driving to duplicate the conditions can isolate many of these incidents. The areas can usually be insulated with felt cloth tape or insulator foam blocks from the Nissan Squeak and Rattle Kit (J-43980) to repair the noise.

## TRUNK

Trunk noises are often caused by a loose jack or loose items put into the trunk by the customer.

In addition look for the following:

1. Trunk lid dumpers out of adjustment

A

B

C

D

E

F

G

H

I

J

EXT

L

M

N

O

P

# SQUEAK AND RATTLE TROUBLE DIAGNOSES

## < SYMPTOM DIAGNOSIS >

---

2. Trunk lid striker out of adjustment
3. The trunk lid torsion bars knocking together
4. A loose license plate or bracket

Most of these incidents can be repaired by adjusting, securing or insulating the item(s) or component(s) causing the noise.

## SUNROOF/HEADLINING

Noises in the sunroof/headlining area can often be traced to one of the following:

1. Sunroof lid, rail, linkage or seals making a rattle or light knocking noise
2. Sunvisor shaft shaking in the holder
3. Front or rear windshield touching headlining and squeaking

Again, pressing on the components to stop the noise while duplicating the conditions can isolate most of these incidents. Repairs usually consist of insulating with felt cloth tape.

## SEATS

When isolating seat noise it's important to note the position the seats in and the load placed on the seat when the noise occurs. These conditions should be duplicated when verifying and isolating the cause of the noise.

Cause of seat noise include:

1. Headrest rods and holder
2. A squeak between the seat pad cushion and frame
3. The rear seatback lock and bracket

These noises can be isolated by moving or pressing on the suspected components while duplicating the conditions under which the noise occurs. Most of these incidents can be repaired by repositioning the component or applying urethane tape to the contact area.

## UNDERHOOD

Some interior noise may be caused by components under the hood or on the engine wall. The noise is then transmitted into the passenger compartment.

Causes of transmitted underhood noise include:

1. Any component mounted to the engine wall
2. Components that pass through the engine wall
3. Engine wall mounts and connectors
4. Loose radiator mounting pins
5. Hood bumpers out of adjustment
6. Hood striker out of adjustment

These noises can be difficult to isolate since they cannot be reached from the interior of the vehicle. The best method is to secure, move or insulate one component at a time and test drive the vehicle. Also, engine RPM or load can be changed to isolate the noise. Repairs can usually be made by moving, adjusting, securing, or insulating the component causing the noise.

# SQUEAK AND RATTLE TROUBLE DIAGNOSES

< SYMPTOM DIAGNOSIS >

## Diagnostic Worksheet

INFOID:000000004678286



### SQUEAK & RATTLE DIAGNOSTIC WORKSHEET

Dear Infiniti Customer:

We are concerned about your satisfaction with your Infiniti vehicle. Repairing a squeak or rattle sometimes can be very difficult. To help us fix your Infiniti right the first time, please take a moment to note the area of the vehicle where the squeak or rattle occurs and under what conditions. You may be asked to take a test drive with a service consultant or technician to ensure we confirm the noise you are hearing.

#### I. WHERE DOES THE NOISE COME FROM? (circle the area of the vehicle)

The illustrations are for reference only, and may not reflect the actual configuration of your vehicle.

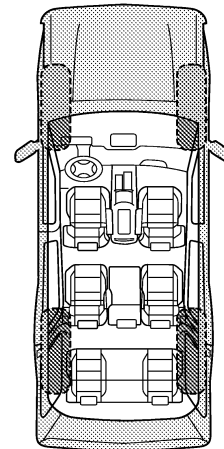
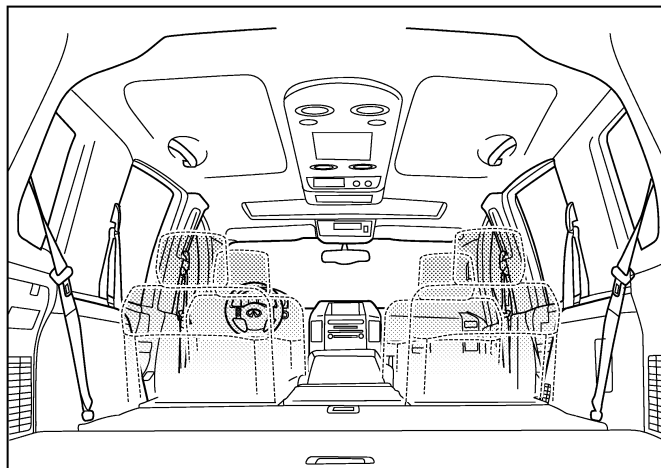
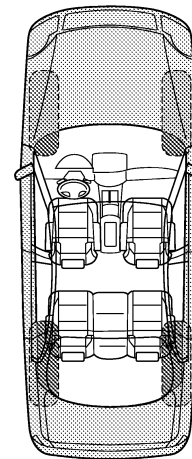
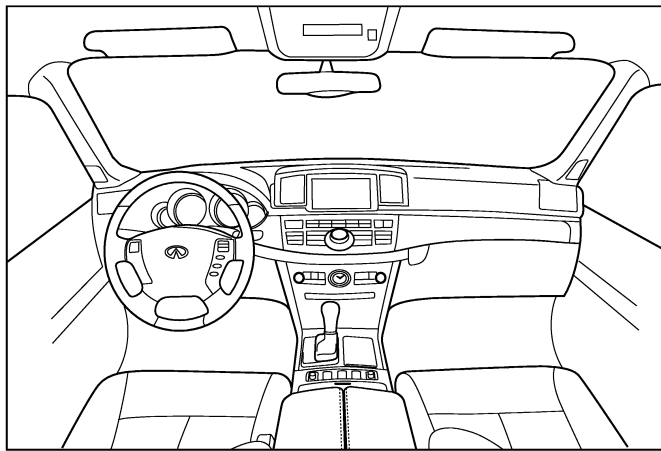

Continue to page 2 of the worksheet and briefly describe the location of the noise or rattle. In addition, please indicate the conditions which are present when the noise occurs.

PIIB8741E

A  
B  
C  
D  
E  
F  
G  
H  
I  
J  
EXT  
L  
M  
N  
O  
P

# SQUEAK AND RATTLE TROUBLE DIAGNOSES

< SYMPTOM DIAGNOSIS >

## SQUEAK & RATTLE DIAGNOSTIC WORKSHEET - page 2

Briefly describe the location where the noise occurs:

---

---

### II. WHEN DOES IT OCCUR? (please check the boxes that apply)

- |   |  |
|---|--|
| <input type="checkbox"/> anytime                      | <input type="checkbox"/> after sitting out in the rain |
| <input type="checkbox"/> 1st time in the morning      | <input type="checkbox"/> when it is raining or wet     |
| <input type="checkbox"/> only when it is cold outside | <input type="checkbox"/> dry or dusty conditions       |
| <input type="checkbox"/> only when it is hot outside  | <input type="checkbox"/> other:                        |

### III. WHEN DRIVING:

- through driveways
- over rough roads
- over speed bumps
- only about \_\_\_\_ mph
- on acceleration
- coming to a stop
- on turns: left, right or either (circle)
- with passengers or cargo
- other: \_\_\_\_\_
- after driving \_\_\_\_ miles or \_\_\_\_ minutes

### IV. WHAT TYPE OF NOISE

- squeak (like tennis shoes on a clean floor)
- creak (like walking on an old wooden floor)
- rattle (like shaking a baby rattle)
- knock (like a knock at the door)
- tick (like a clock second hand)
- thump (heavy, muffled knock noise)
- buzz (like a bumble bee)

## TO BE COMPLETED BY DEALERSHIP PERSONNEL

### Test Drive Notes:

---

---

---

	YES	NO	Initials of person performing
Vehicle test driven with customer	<input type="checkbox"/>	<input type="checkbox"/>	_____
- Noise verified on test drive	<input type="checkbox"/>	<input type="checkbox"/>	_____
- Noise source located and repaired	<input type="checkbox"/>	<input type="checkbox"/>	_____
- Follow up test drive performed to confirm repair	<input type="checkbox"/>	<input type="checkbox"/>	_____

VIN: \_\_\_\_\_ Customer Name: \_\_\_\_\_  
W.O.# \_\_\_\_\_ Date: \_\_\_\_\_

This form must be attached to Work Order

PIIB8742E



# PRECAUTIONS

< PRECAUTION >

## PRECAUTION

### PRECAUTIONS

#### Precaution for Supplemental Restraint System (SRS) "AIR BAG" and "SEAT BELT PRE-TENSIONER"

INFOID:000000004249853

The Supplemental Restraint System such as "AIR BAG" and "SEAT BELT PRE-TENSIONER", used along with a front seat belt, helps to reduce the risk or severity of injury to the driver and front passenger for certain types of collision. This system includes seat belt switch inputs and dual stage front air bag modules. The SRS system uses the seat belt switches to determine the front air bag deployment, and may only deploy one front air bag, depending on the severity of a collision and whether the front occupants are belted or unbelted. Information necessary to service the system safely is included in the "SRS AIR BAG" and "SEAT BELT" of this Service Manual.

#### **WARNING:**

- To avoid rendering the SRS inoperative, which could increase the risk of personal injury or death in the event of a collision which would result in air bag inflation, all maintenance must be performed by an authorized NISSAN/INFINITI dealer.
- Improper maintenance, including incorrect removal and installation of the SRS, can lead to personal injury caused by unintentional activation of the system. For removal of Spiral Cable and Air Bag Module, see the "SRS AIR BAG".
- Do not use electrical test equipment on any circuit related to the SRS unless instructed to in this Service Manual. SRS wiring harnesses can be identified by yellow and/or orange harnesses or harness connectors.

#### PRECAUTIONS WHEN USING POWER TOOLS (AIR OR ELECTRIC) AND HAMMERS

#### **WARNING:**

- When working near the Air Bag Diagnosis Sensor Unit or other Air Bag System sensors with the ignition ON or engine running, DO NOT use air or electric power tools or strike near the sensor(s) with a hammer. Heavy vibration could activate the sensor(s) and deploy the air bag(s), possibly causing serious injury.
- When using air or electric power tools or hammers, always switch the ignition OFF, disconnect the battery, and wait at least 3 minutes before performing any service.

#### Precaution Necessary for Steering Wheel Rotation after Battery Disconnect

INFOID:000000004249854

#### **NOTE:**

- Before removing and installing any control units, first turn the push-button ignition switch to the LOCK position, then disconnect both battery cables.
- After finishing work, confirm that all control unit connectors are connected properly, then re-connect both battery cables.
- Always use CONSULT-III to perform self-diagnosis as a part of each function inspection after finishing work. If a DTC is detected, perform trouble diagnosis according to self-diagnosis results.

For vehicle with steering lock unit, if the battery is disconnected or discharged, the steering wheel will lock and cannot be turned.

If turning the steering wheel is required with the battery disconnected or discharged, follow the operation procedure below before starting the repair operation.

#### OPERATION PROCEDURE

1. Connect both battery cables.

#### **NOTE:**

Supply power using jumper cables if battery is discharged.

2. Turn the push-button ignition switch to ACC position.  
(At this time, the steering lock will be released.)
3. Disconnect both battery cables. The steering lock will remain released with both battery cables disconnected and the steering wheel can be turned.
4. Perform the necessary repair operation.

A  
B  
C  
D  
E  
F  
G  
H  
I  
J  
EXT  
L  
M  
N  
O  
P

# PRECAUTIONS

## < PRECAUTION >

5. When the repair work is completed, re-connect both battery cables. With the brake pedal released, turn the push-button ignition switch from ACC position to ON position, then to LOCK position. (The steering wheel will lock when the push-button ignition switch is turned to LOCK position.)
6. Perform self-diagnosis check of all control units using CONSULT-III.

### Precaution for Battery Service

INFOID:000000004678292

Before disconnecting the battery, lower both the driver and passenger windows. This will prevent any interference between the window edge and the vehicle when the door is opened/closed. During normal operation, the window slightly raises and lowers automatically to prevent any window to vehicle interference. The automatic window function will not work with the battery disconnected.

### Precaution for Procedure without Cowl Top Cover

INFOID:000000004249855

When performing the procedure after removing cowl top cover, cover the lower end of windshield with urethane, etc.

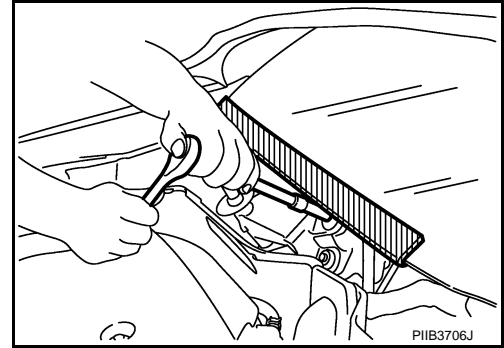

### Precaution for Work

INFOID:000000004249856

- After removing and installing the opening/closing parts, be sure to carry out fitting adjustments to check their operation.
- Check the lubrication level, damage, and wear of each part. If necessary, grease or replace it.

# PREPARATION

< PREPARATION >

## PREPARATION

### PREPARATION

#### Special Service Tools

INFOID:000000004249857

The actual shapes of Kent-Moore tools may differ from those of special service tools illustrated here.

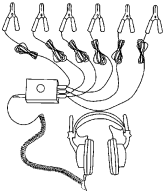
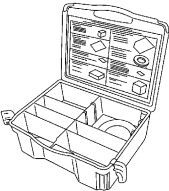
Tool number (Kent-Moore No.) Tool name	Description
<p>(J-39570) Chassis ear</p>  <p>SIIA0993E</p>	<p>Locates the noise</p>
<p>(J-43980) NISSAN Squeak and Rattle Kit</p>  <p>SIIA0994E</p>	<p>Repaires the cause of noise</p>

#### Commercial Service Tools

INFOID:000000004249858

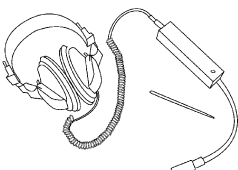
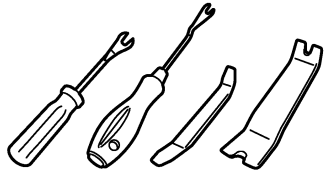
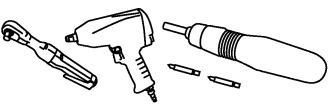
Tool name	Description
<p>Engine ear</p>  <p>SIIA0995E</p>	<p>Locates the noise</p>
<p>Remover tool</p>  <p>JMKIA3050ZZ</p>	<p>Removes clips, pawls and metal clips</p>
<p>Power tool</p>  <p>PIIB1407E</p>	

A

B

C

D

E

F

G

H

I

J

EXT

L

M

N

O

P

# FRONT BUMPER

< REMOVAL AND INSTALLATION >

## REMOVAL AND INSTALLATION

### FRONT BUMPER

Exploded View

INFOID:000000004249859

SEC. 620

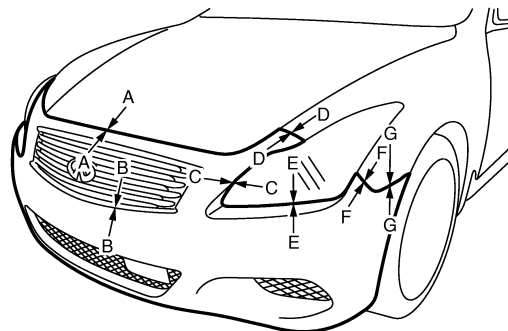
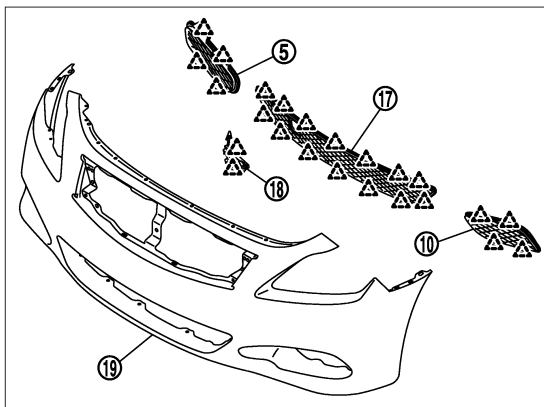
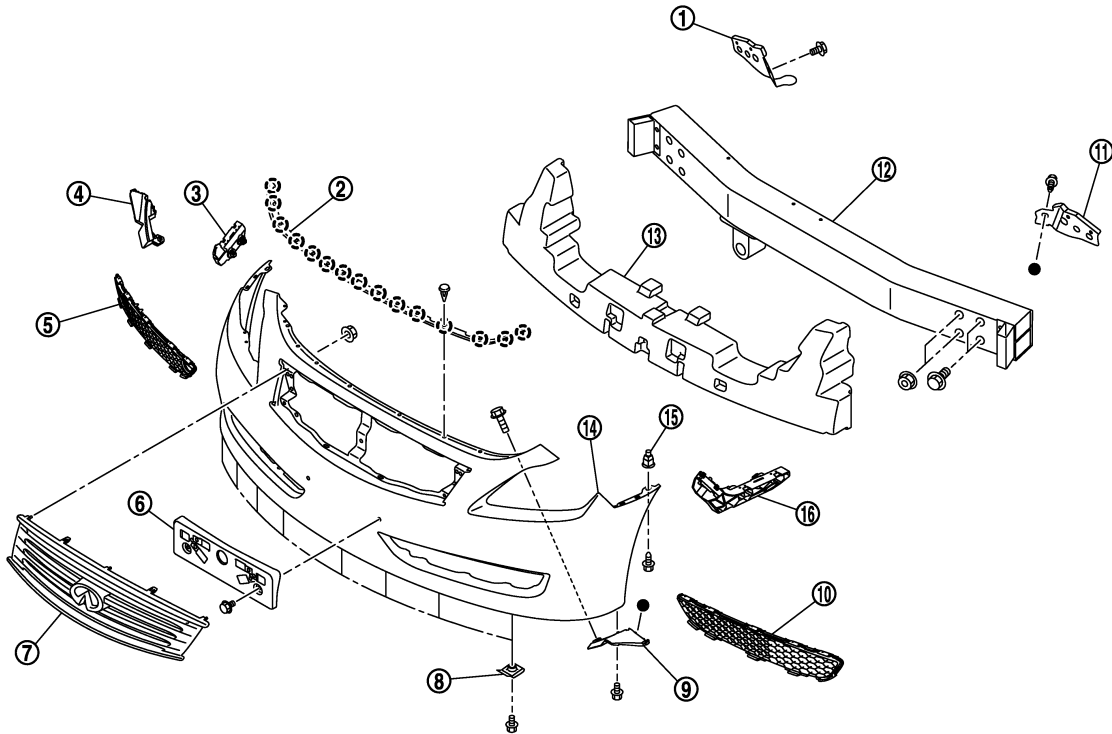

JMKIA1225ZZ

- |                             |                                     |                             |
|-----------------------------|-------------------------------------|-----------------------------|
| 1. Bumper bracket RH        | 2. Hood seal assembly (front)       | 3. Bumper side bracket RH   |
| 4. Bumper side stiffener RH | 5. Bumper finisher RH               | 6. License plate bracket    |
| 7. Front grille             | 8. J-nut                            | 9. Bumper side stiffener LH |
| 10. Bumper finisher LH      | 11. Bumper bracket LH               | 12. Bumper reinforcement    |
| 13. Energy absorber         | 14. Bumper fascia assembly (normal) | 15. Grommet                 |

# FRONT BUMPER

## < REMOVAL AND INSTALLATION >

- 16. Bumper side bracket LH
- 17. Bumper finisher (center)
- 18. Bumper bracket cover
- 19. Bumper fascia assembly (sports)

○ : Clip

△ : Pawl

## Removal and Installation

INFOID:000000004249860

### REMOVAL

#### CAUTION:

Bumper fascia is made of resin. Never apply strong force to it, and be careful to prevent contact with oil.

1. Fully open hood assembly.
2. Remove clips (A) of front bumper fascia upper side.

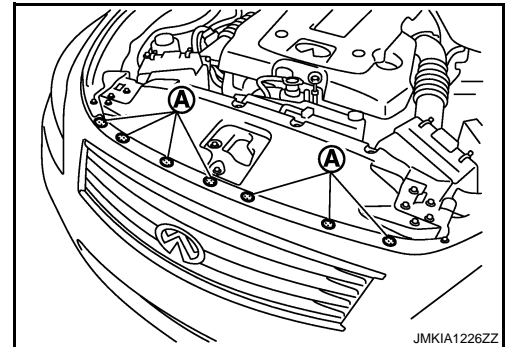

3. Remove radiator core support ornament. Refer to [DLK-212. "Removal and Installation"](#).
4. Remove clips (A) of hood seal assembly (side) (LH/RH) with remover tool (B), and then remove hood seal assembly located front portion. Refer to [DLK-215. "Removal and Installation"](#).

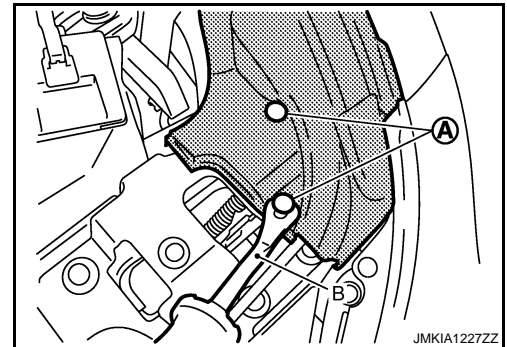

5. Remove bolts (A), and then remove bumper bracket (1) (LH/RH).

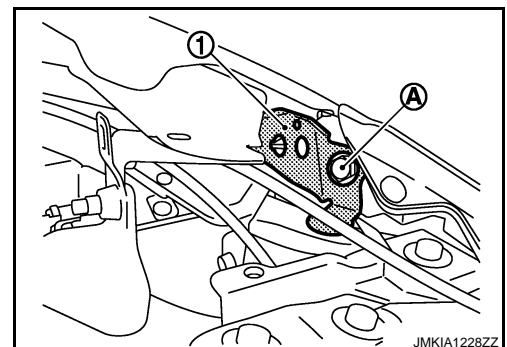

A  
B  
C  
D  
E  
F  
G  
H  
I  
J  
EXT  
L  
M  
N  
O  
P

# FRONT BUMPER

## < REMOVAL AND INSTALLATION >

6. Remove bolts (A) of fixing engine lower cover and front fender protector.

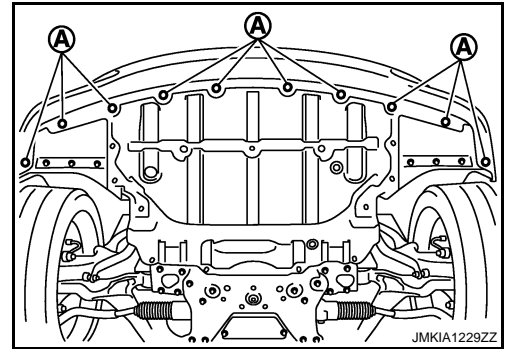

7. Remove fender protector (front) mounting bolts and clips, and then remove screw (A) of fixing bumper fascia left and right side.

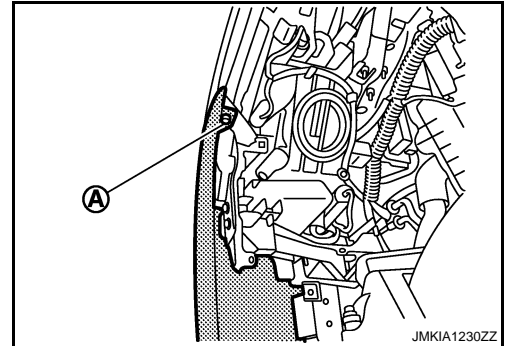

8. Pull the bumper fascia side toward the vehicle side to disengage the fitting of bumper side bracket and bumper fascia side.

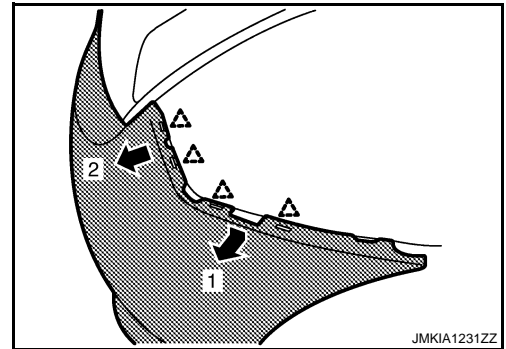

9. Remove bumper fascia assembly.

**CAUTION:**

**When removing bumper fascia, 2 workers are required so as to prevent it from dropping.**

10. Remove the following parts after removing bumper fascia.

- Front grille
- Hood seal assembly (front)
- License plate bracket
- Front bumper side bracket (LH/RH)
- Front bumper side stiffener (LH/RH)
- Front bumper finisher

11. Remove bumper energy absorber.

12. Remove bumper reinforcement mounting nuts and bolts, and then remove bumper reinforcement with power tool.

## INSTALLATION

Install in the reverse order of removal.

**NOTE:**

After installing, perform fitting adjustment.

Portion		Clearance
Front bumper – Hood assembly	A – A	2.0 – 4.5 mm (0.079 – 0.177 in)
Front bumper – Front grille	B – B	0.2 – 2.8 mm (0.008 – 0.110 in)

# FRONT BUMPER

< REMOVAL AND INSTALLATION >

Portion		Clearance
Front bumper – Headlamp	C – C	0.5 – 3.2 mm (0.020 – 0.126 in)
Front bumper – Front fender	D – D	0.0 – 0.7 mm (0.000 – 0.028 in)
Front bumper – Headlamp	E – E	0.3 – 3.2 mm (0.012 – 0.126 in)
Front bumper – Front fender	F – F	0.0 – 0.7 mm (0.000 – 0.028 in)
Front bumper – Front fender	G – G	0.0 – 0.8 mm (0.000 – 0.031 in)

A  
B  
C  
D  
E  
F  
G  
H  
I  
J  
L  
M  
N  
O  
P

EXT

# REAR BUMPER

< REMOVAL AND INSTALLATION >

## REAR BUMPER

Exploded View

INFOID:000000004249861

SEC. 850

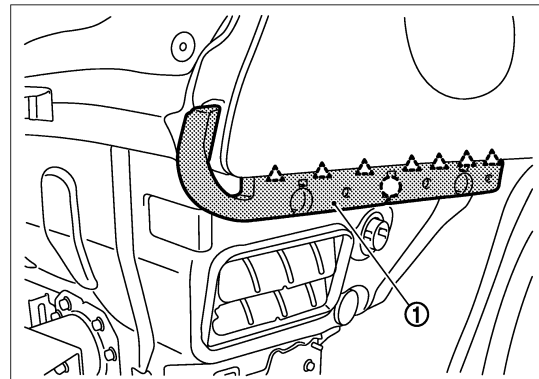
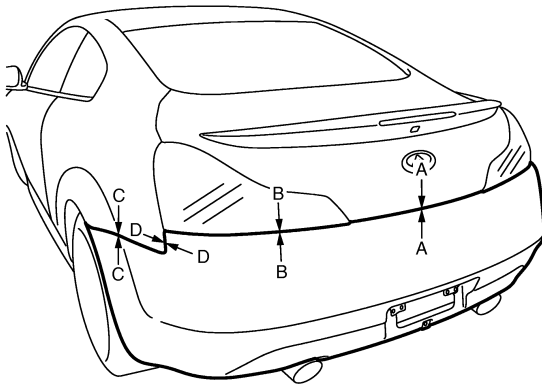
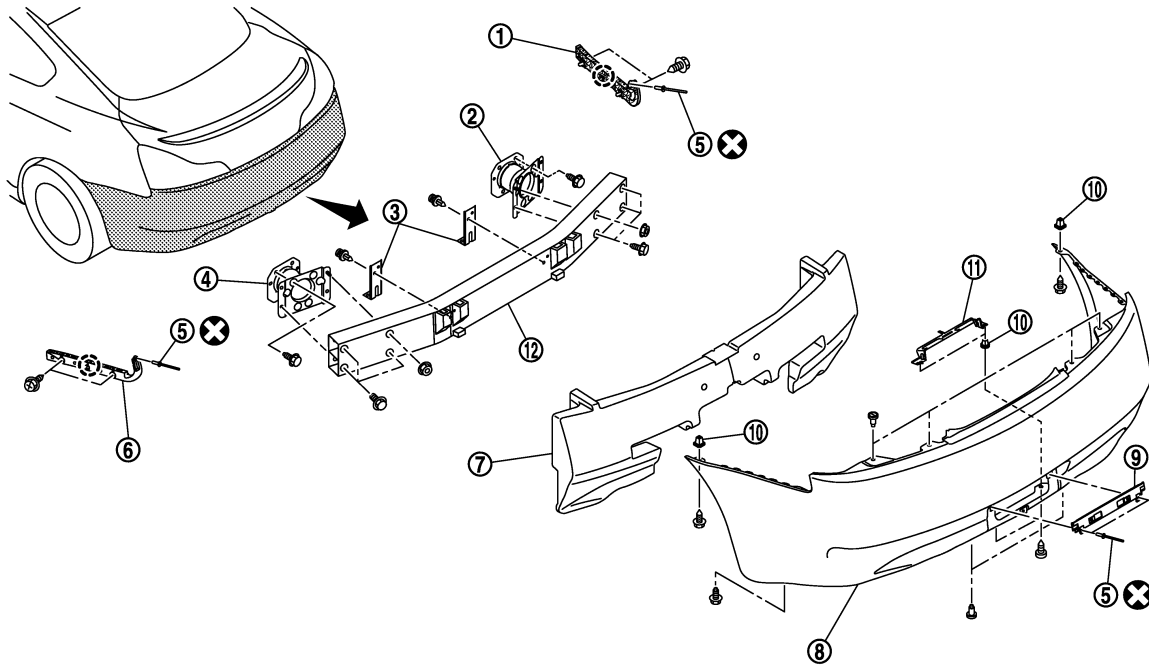

JMKIA1232ZZ

- |                           |                           |                               |
|---------------------------|---------------------------|-------------------------------|
| 1. Bumper side bracket RH | 2. Bumper stay RH         | 3. Bumper lower retainer      |
| 4. Bumper stay LH         | 5. Rivet                  | 6. Bumper side bracket LH     |
| 7. Bumper energy absorber | 8. Bumper fascia assembly | 9. Rear license plate bracket |
| 10. Grommet               | 11. License lamp bracket  | 12. Bumper reinforcement      |

⊖ : Clip



# REAR BUMPER

## < REMOVAL AND INSTALLATION >

 : Pawl

Refer to [GI-4, "Components"](#) for symbols in the figure.

### Removal and Installation

INFOID:000000004249862

#### REMOVAL

##### **CAUTION:**

**Bumper fascia is made of resin. Never apply strong force to it, and be careful to prevent contact with oil.**

1. Fully open trunk lid assembly.
2. Remove rear combination lamp (LH/RH). Refer to [EXL-203, "Removal and Installation"](#).
3. Remove clips (A) located under rear combination lamp (LH/RH).

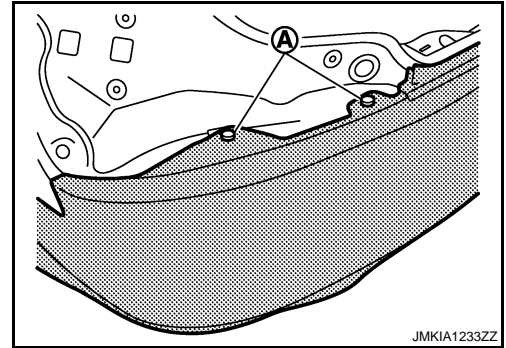

4. Remove bolts (A) of bumper fascia underside (LH/RH).

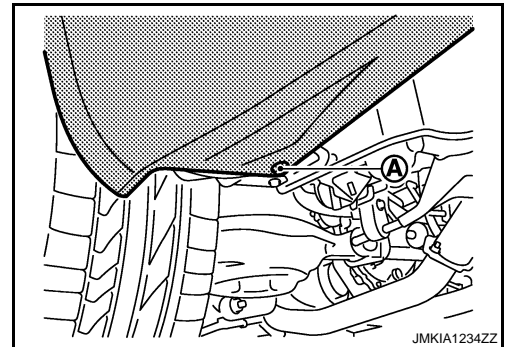

5. Remove screws (A) of bumper fascia front end upper (LH/RH).

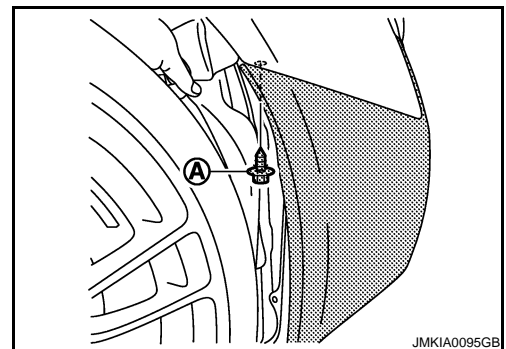

6. Remove clips of bumper fascia underside, and then pull out bumper fascia toward rear of vehicle.

A  
B  
C  
D  
E  
F  
G  
H  
I  
J  
EXT  
L  
M  
N  
O  
P

# REAR BUMPER

## < REMOVAL AND INSTALLATION >

7. Disconnect license plate lamp connector (A).

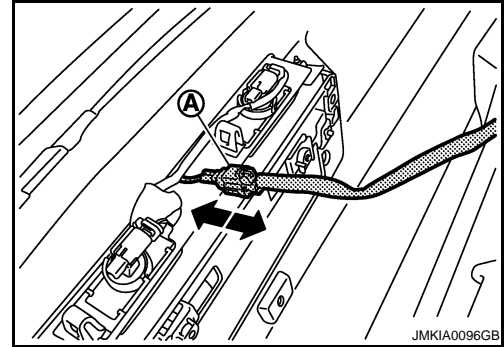

8. Pull the bumper fascia side toward the vehicle side to disengage the fitting of bumper side bracket and bumper fascia side.

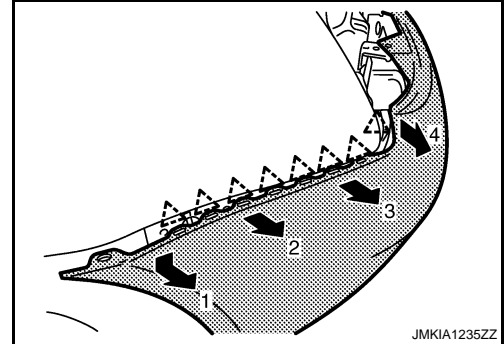

9. Remove bumper fascia assembly.

**CAUTION:**

**When removing bumper fascia, 2 workers are required so as to prevent it from dropping.**

10. Remove the following parts after removing bumper fascia.

- License plate lamp. Refer to [EXL-207. "Removal and Installation"](#).
- License lamp bracket.
- License plate bracket.
- Bumper lower retainer.

11. Remove bumper energy absorber.

12. Remove license lamp harness clamps of bumper reinforcement.

13. Remove bumper reinforcement mounting nuts and bolts, and then remove bumper reinforcement with power tool.

## INSTALLATION

Install in the reverse order of removal.

**NOTE:**

After installing, perform fitting adjustment.

Portion		Clearance
Rear bumper – Trunk lid	A – A	4.0 – 8.0 mm (0.157 – 0.315 in)
Rear bumper – Rear combination lamp	B – B	0.0 – 3.0 mm (0.000 – 0.118 in)
Rear bumper – Rear fender	C – C	0.0 – 0.8 mm (0.000 – 0.031 in)
Rear bumper – Rear fender	D – D	0.0 – 0.8 mm (0.000 – 0.031 in)

# FRONT GRILLE

< REMOVAL AND INSTALLATION >

## FRONT GRILLE

Exploded View

INFOID:000000004249863

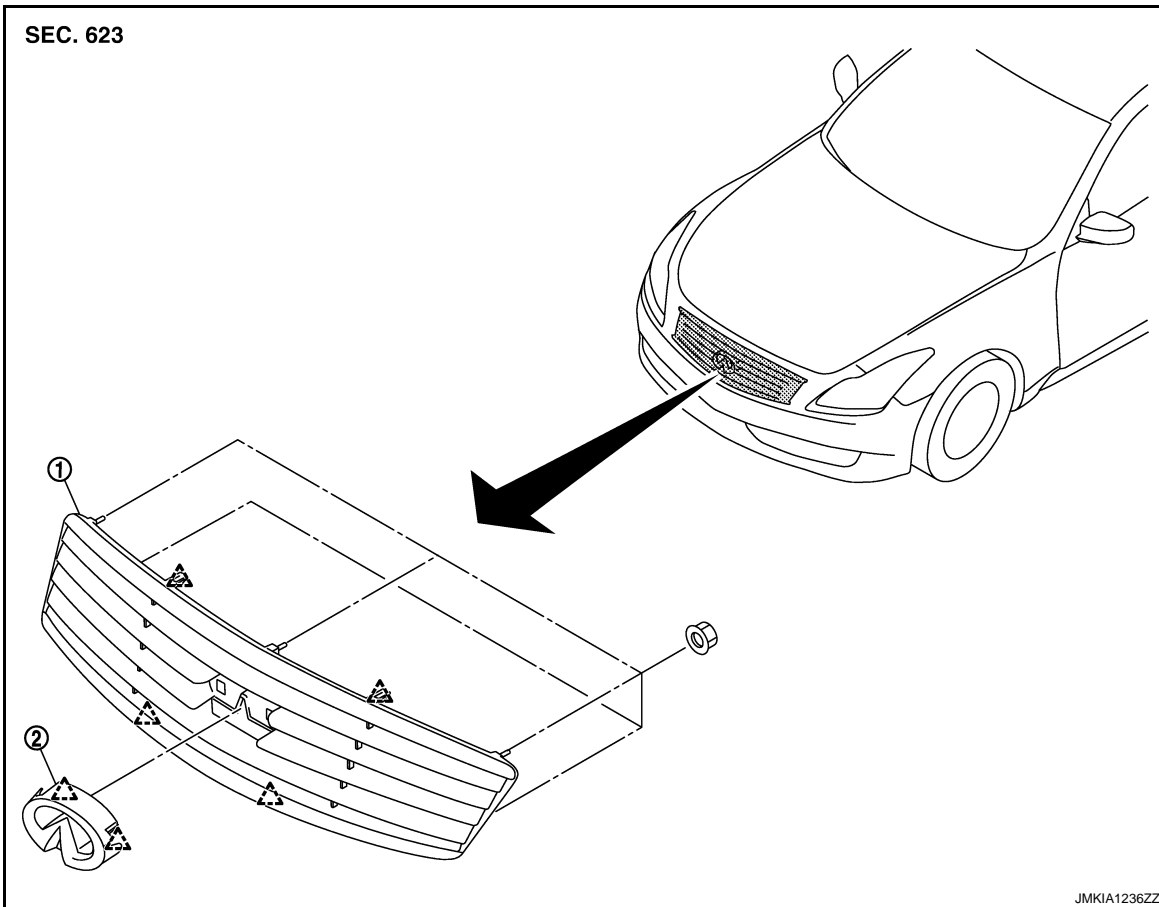

1. Front grille

2. Front emblem

△ : Pawl

## Removal and Installation

INFOID:000000004249864

### REMOVAL

#### CAUTION:

Apply protection tape around outer circumference of front grille (bumper fascia side).

1. Fully open hood assembly.
2. Remove reservoir tank. Refer to [CO-14. "Removal and Installation"](#).
3. Remove radiator core support ornament. Refer to [DLK-212. "Removal and Installation"](#).
4. Remove front grille mounting nuts (A).

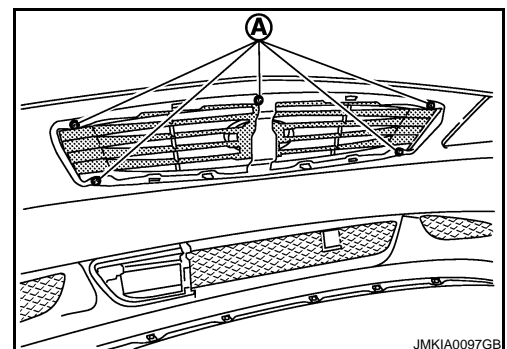

## FRONT GRILLE

### < REMOVAL AND INSTALLATION >

5. Disengage pawls (A) of fixing front grille.

 : Pawl

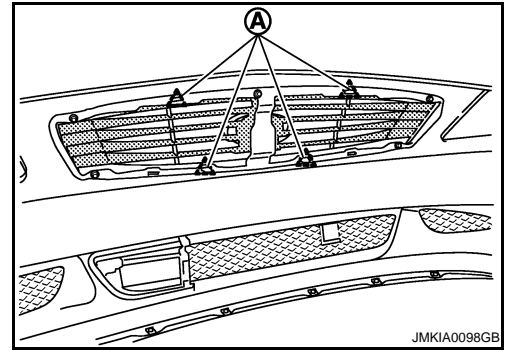

6. Pull front grille out toward vehicle front.
7. Remove the following parts after removing front grille.  
Front emblem

### INSTALLATION

Install in the reverse order of removal.

# COWL TOP

< REMOVAL AND INSTALLATION >

## COWL TOP

Exploded View

INFOID:000000004249865

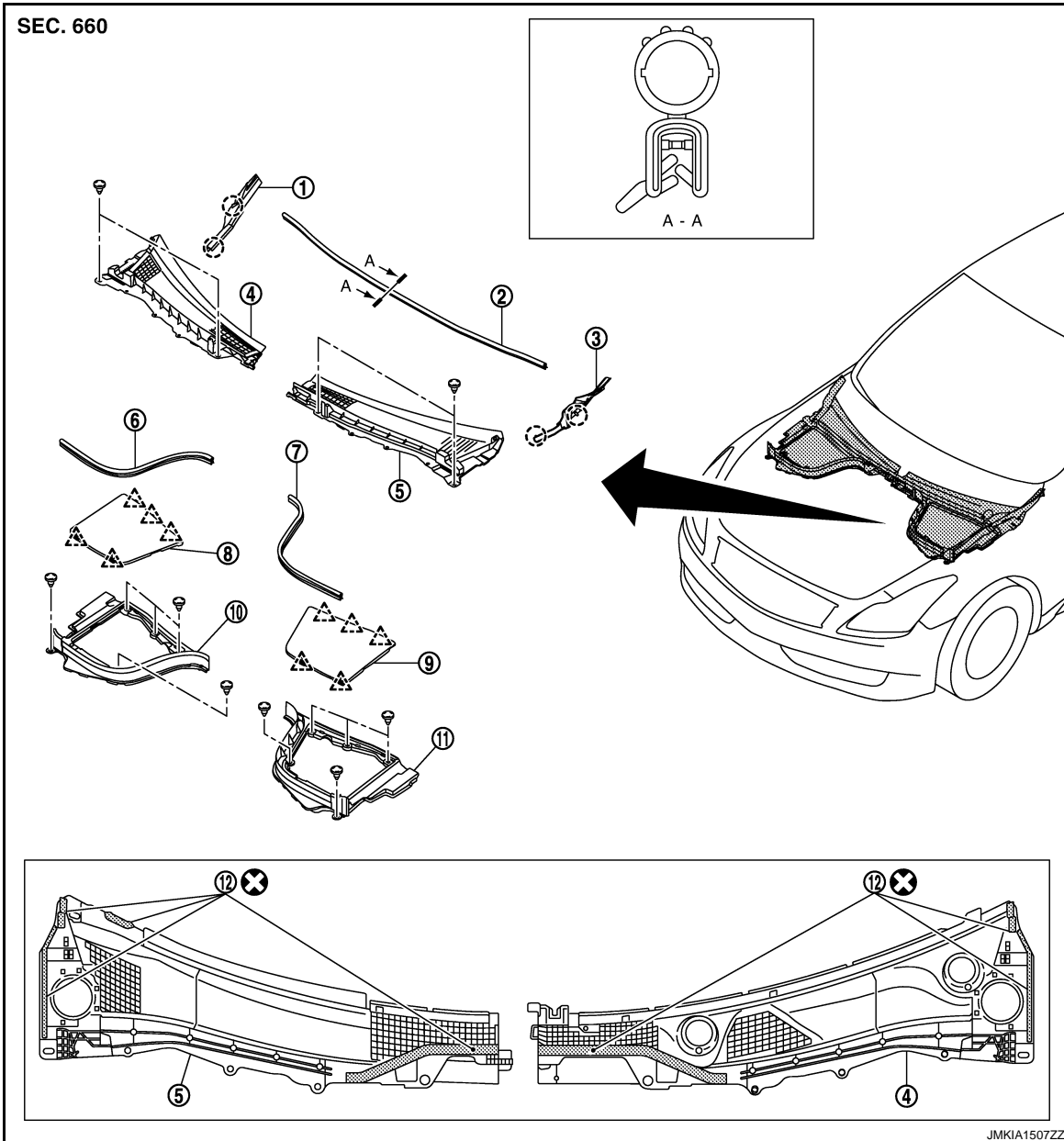

- |                             |                          |                                |
|-----------------------------|--------------------------|--------------------------------|
| 1. Front fender cover (RH)  | 2. Cowl top seal         | 3. Front fender cover (LH)     |
| 4. Cowl top cover (RH)      | 5. Cowl top cover (LH)   | 6. Cowl top cover seal (RH)    |
| 7. Cowl top cover seal (LH) | 8. Battery cover         | 9. Brake master cylinder cover |
| 10. Hoodledge cover (RH)    | 11. Hoodledge cover (LH) | 12. EPT sealer                 |

○ : Clip

△ : Pawl

Refer to [GI-4, "Components"](#) for symbols in the figure.

## Removal and Installation

INFOID:000000004249866

### REMOVAL

1. Fully open hood assembly.

A  
B  
C  
D  
E  
F  
G  
H  
I  
J  
EXT  
L  
M  
N  
O  
P

## COWL TOP

### < REMOVAL AND INSTALLATION >

2. Remove front wiper arm (LH/RH) from vehicle. Refer to [WW-93. "Removal and Installation"](#).
3. Remove battery cover and brake master cylinder cover.
4. Remove hoodledge cover mounting clips and then remove hoodledge cover (LH/RH) and cowl top cover seal (LH/RH).
5. Remove cowl top seal.
6. Remove cowl top cover mounting clips.
7. Plastic pawl (A) is pull up and cowl top cover RH (2) is removed ahead of vehicles.

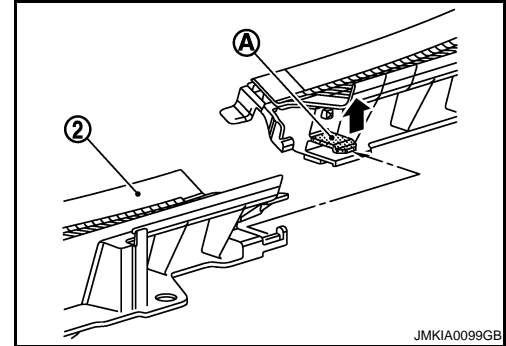

8. Plastic pawl (B) is push down and cowl top cover LH (1) is removed ahead of vehicles.

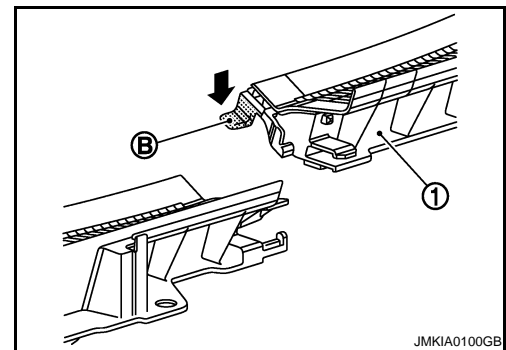

9. Remove the following parts after removing cowl top cover.
  - Front fender cover (LH/RH).
  - EPT sealer.

### INSTALLATION

Note the following, and install in the reverse order of removal.

- Install cowl top cover LH (1) with (C) (pin from front windshield glass) aligned with concave part.

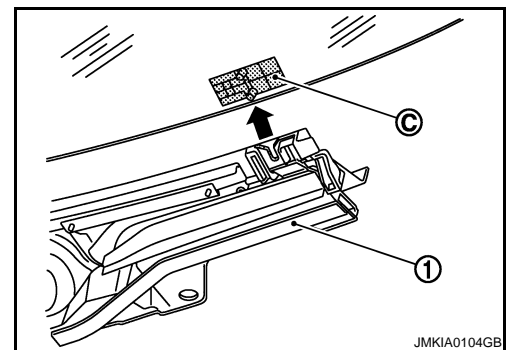

## COWL TOP

### < REMOVAL AND INSTALLATION >

- Slide the pawl while aligning with the concave part of (E).
- Engage the joint of plastic pawl of (A) with (D), and then assemble cowl top covers LH (1) and RH (2).

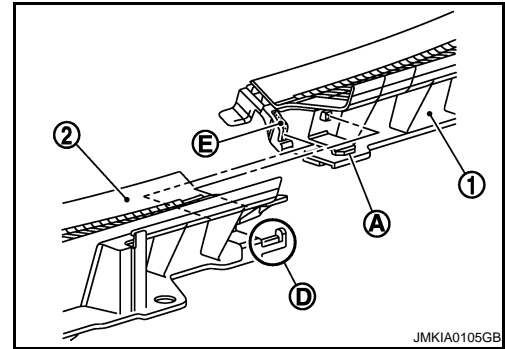

### **CAUTION:**

After installing, perform adjustment of wiper arm. Refer to [WW-93, "Adjustment"](#).

A  
B  
C  
D  
E  
F  
G  
H  
I  
J  
L  
M  
N  
O  
P

EXT

# FENDER PROTECTOR

< REMOVAL AND INSTALLATION >

## FENDER PROTECTOR

## FENDER PROTECTOR

## FENDER PROTECTOR : Exploded View

INFOID:000000004249867

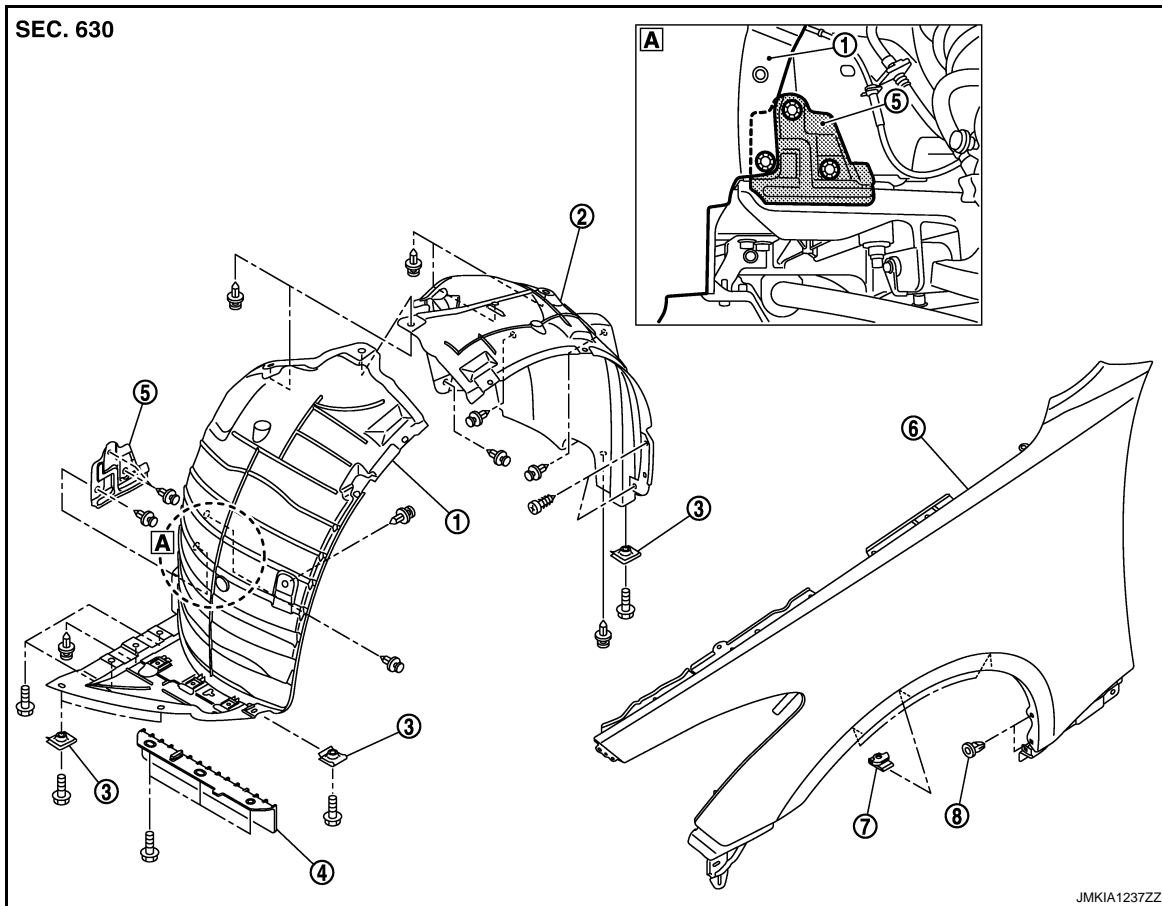

- |                             |                            |                 |
|-----------------------------|----------------------------|-----------------|
| 1. Fender protector (front) | 2. Fender protector (rear) | 3. J-nut        |
| 4. Fairing                  | 5. Splash guard            | 6. Front fender |
| 7. Fender clip              | 8. Grommet                 |                 |

## FENDER PROTECTOR : Removal and Installation

INFOID:000000004249868

### REMOVAL

1. Remove bolt (A) of fender protector (rear) rear end.
2. Remove screws (B) of fender protector (rear) located center mud guard and front fender.

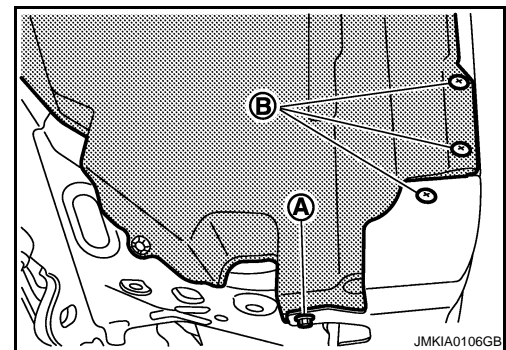

3. Remove clips of fender protector (rear).
4. Remove fender clip from wheelhouse arches, and then remove fender protector (rear) from wheel house.



# FENDER PROTECTOR

## < REMOVAL AND INSTALLATION >

5. Remove bolts (A) of fender protector (front) located engine under cover and front bumper.

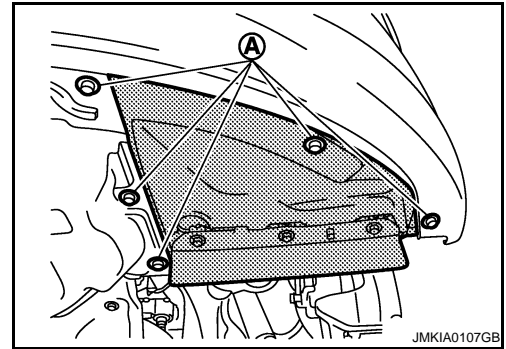

6. Remove fender protector (front) mounting clips.
7. Remove fender clip from wheel house arches, and then remove fender protector (front) from wheel house.
8. Remove the following parts after removing front fender protector.
  - Fairing
  - Fender clip

## INSTALLATION

Install in the reverse order of removal.

## REAR WHEEL HOUSE PROTECTOR

### REAR WHEEL HOUSE PROTECTOR : Exploded View

INFOID:000000004249869

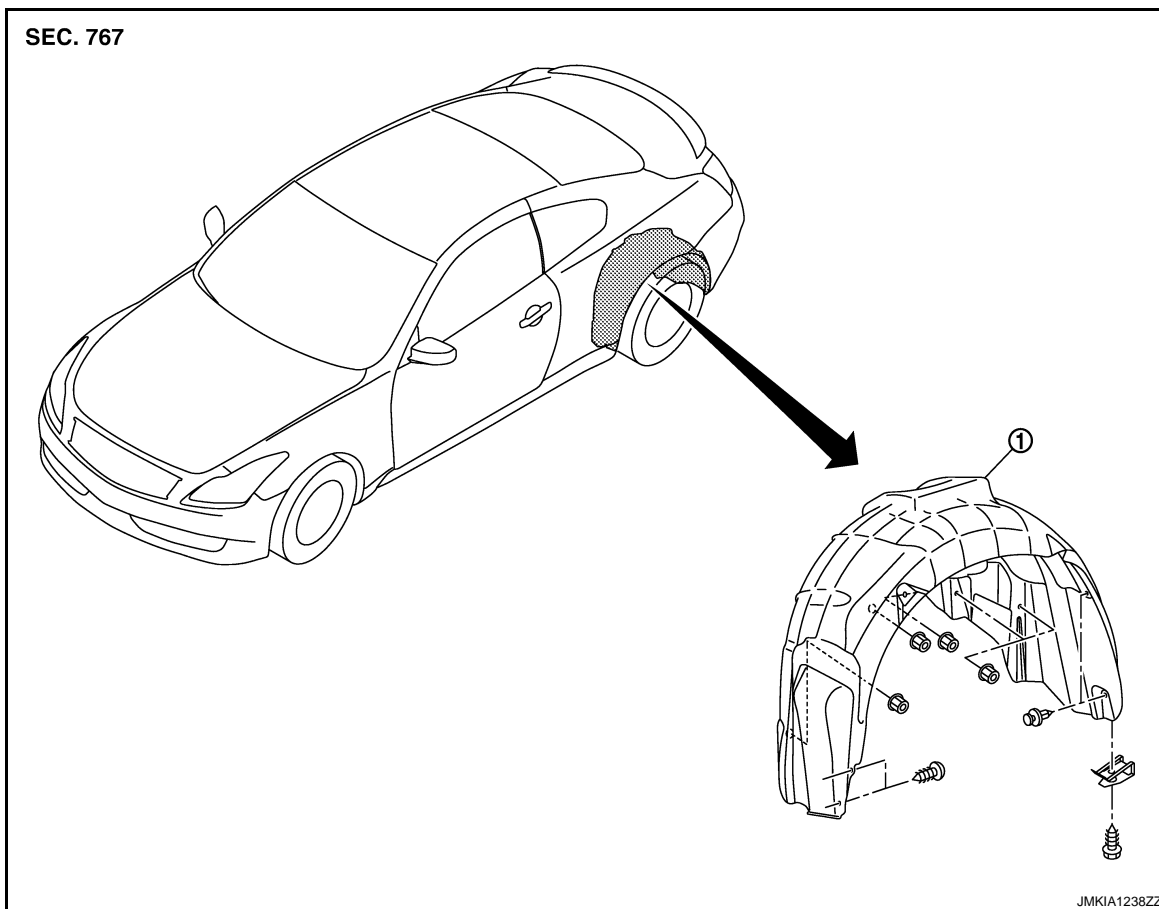

1. Rear wheel house protector

### REAR WHEEL HOUSE PROTECTOR : Removal and Installation

INFOID:000000004249870

## REMOVAL

A  
B  
C  
D  
E  
F  
G  
H  
I  
J  
EXT  
L  
M  
N  
O  
P

## FENDER PROTECTOR

### < REMOVAL AND INSTALLATION >

1. Remove bolt (A) of rear wheel house protector rear end.

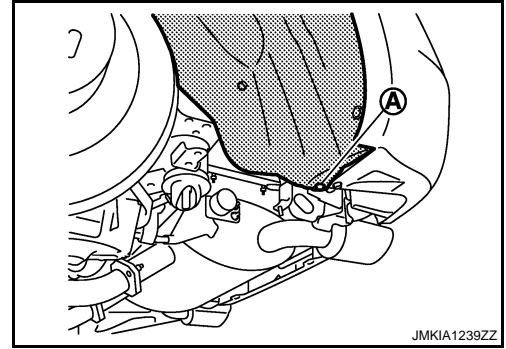

2. Remove screw (A) of rear wheel house protector located center mud guard.

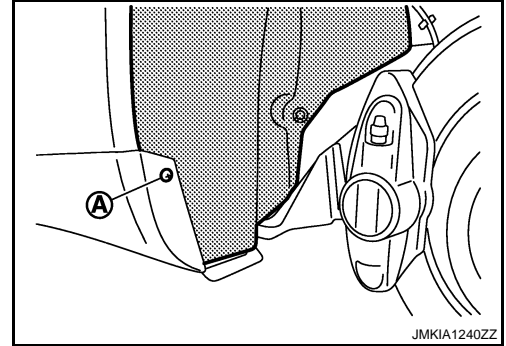

3. Remove rear wheel house protector mounting nuts and then remove rear wheel house protector.

### INSTALLATION

Install in the reverse order of removal.

# CENTER MUD GUARD

< REMOVAL AND INSTALLATION >

## CENTER MUD GUARD

Exploded View

INFOID:000000004249871

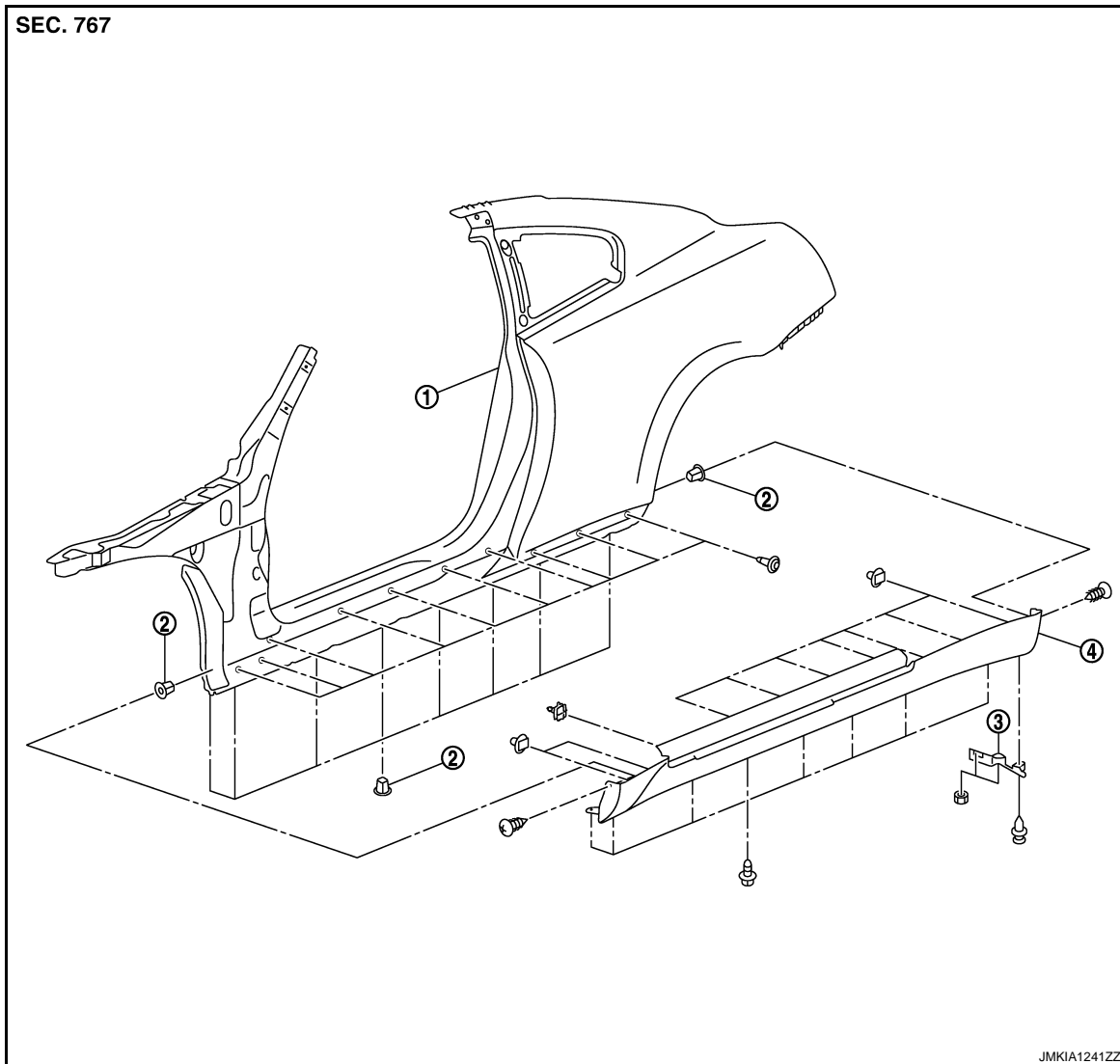

- 1. Body side outer
- 2. Grommet
- 3. Wind deflector
- 4. Center mud guard

### Removal and Installation

INFOID:000000004613636

#### REMOVAL

1. Remove wind deflector mounting clip (A) and nuts (B), and then remove wind deflector (1).

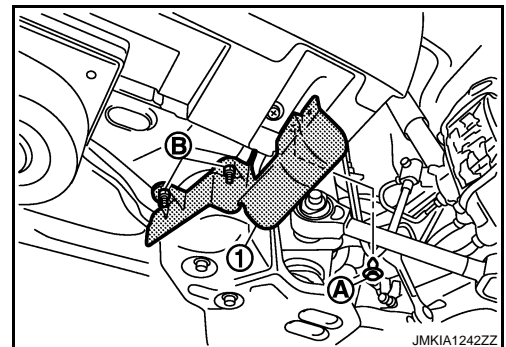

## CENTER MUD GUARD

### < REMOVAL AND INSTALLATION >

2. Remove screw (A) and bolt (B) of center mud guard front end.

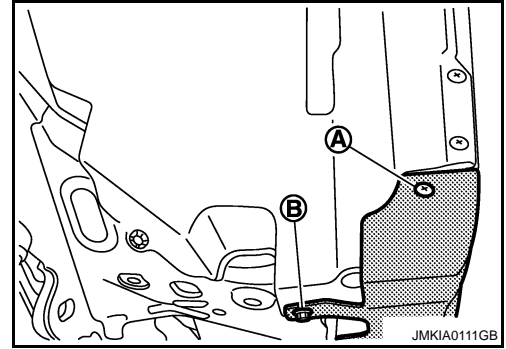

3. Remove screw (A) of center mud guard rear end.

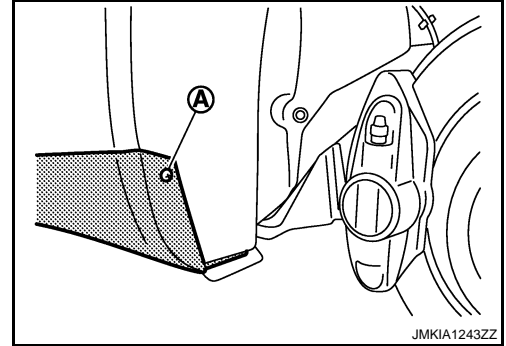

4. Remove screws of center mud guard underside.
5. Fully open front door.
6. Remove clips from back of center mud guard using remover tool.
7. Remove center mud guard from body side.

### INSTALLATION

Install in the reverse order of removal.

#### **CAUTION:**

**When installing center mud guard, check that clips are securely fitted in panel holes on body, and then press them in.**

# FLOOR SIDE FAIRING

< REMOVAL AND INSTALLATION >

## FLOOR SIDE FAIRING

Exploded View

INFOID:000000004249873

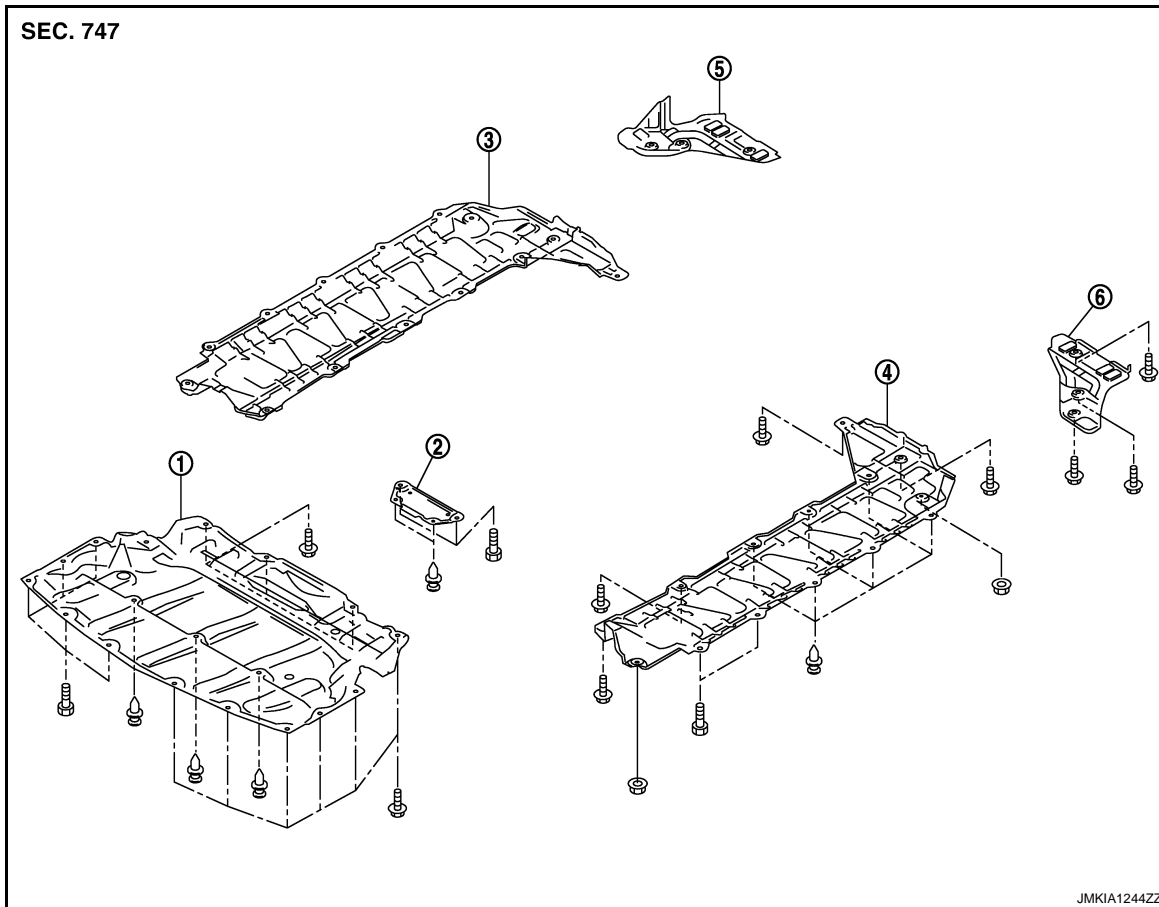

- |                         |                        |                         |
|-------------------------|------------------------|-------------------------|
| 1. Engine lower cover   | 2. Front under cover   | 3. Floor under cover RH |
| 4. Floor under cover LH | 5. Rear under cover RH | 6. Rear under cover LH  |

## Removal and Installation

INFOID:000000004249874

### REMOVAL

#### ENGINE LOWER COVER

1. Remove engine lower cover mounting clips.
2. Remove engine lower cover mounting bolts with power tool.
3. Remove engine lower cover.

#### FRONT UNDER COVER

1. Remove front under cover mounting clips.
2. Remove front under cover mounting bolts with power tool.
3. Remove front under cover.

#### FLOOR UNDER COVER (LH/RH)

1. Remove floor under cover mounting clips.
2. Remove floor under cover mounting bolts and nuts with power tool.
3. Remove floor under cover.

#### REAR UNDER COVER (LH/RH)

1. Remove rear under cover mounting bolts.

A  
B  
C  
D  
E  
F  
G  
H  
I  
J

EXT

L  
M  
N  
O  
P

## FLOOR SIDE FAIRING

### < REMOVAL AND INSTALLATION >

---

2. Remove rear under cover.

### INSTALLATION

Install in the reverse order of removal.

# ROOF SIDE MOLDING

< REMOVAL AND INSTALLATION >

## ROOF SIDE MOLDING

Exploded View

INFOID:000000004249875

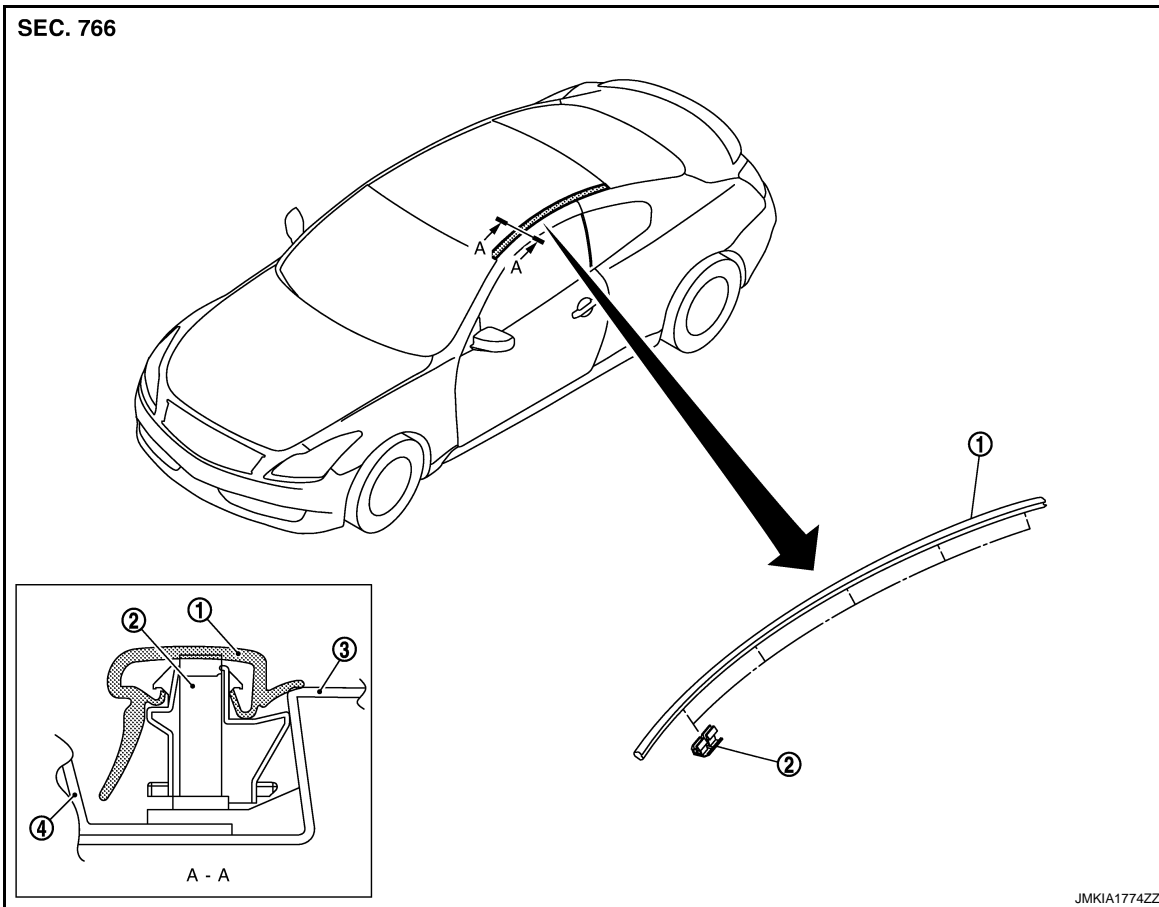

- 1. Roof side molding
- 2. Roof side molding clip
- 3. Body side panel
- 4. Roof panel

### Removal and Installation

INFOID:000000004249876

#### REMOVAL

Disengage roof side molding (1) fixing clips with remover tool (A).

**CAUTION:**

**Wrap the tip of remover tool (A) with a cloth (B).**

 : Clip

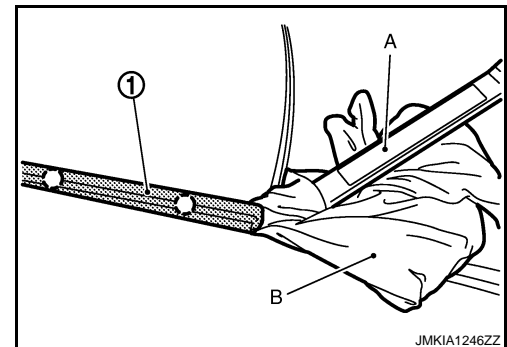

#### INSTALLATION

Install from roof side molding rear end to front end in this order after temporarily holding.

#### REMOVAL AND INSTALLATION OF ROOF SIDE MOLDING CLIP

Removal

1. Remove roof side molding.

A  
B  
C  
D  
E  
F  
G  
H  
I  
J

EXT

L  
M  
N  
O  
P

## ROOF SIDE MOLDING

### < REMOVAL AND INSTALLATION >

---

2. Heat adhesive tape interface using a dryer, and then peel roof side molding clips (body side) using long-nose pliers.

#### **CAUTION:**

**Be careful not to damage the body.**

#### Installation

1. Clean tape removed surface with a shop cloth soaked in white gasoline or IPA.
2. Use two-part epoxy adhesive.

**Adhesive : 3M-weld DP-100 or equivalent**

3. Apply adhesive evenly to clip tape surface.

**Thickness : Approximately 0.5 mm (0.020 in)**

4. Position applied parts to the proper location, and then sufficiently press-fit until the adhesive protrudes to tape side.

**Press-fit limit : 19.6 N × 2 seconds**

5. Tape clips after press fit, and temporarily hold it for specified time based on the following.

**5 to 10°C (41 to 50°F) : 1 hour or more**

**11 to 23°C (52 to 73°F) : 30 minutes or more**

**24°C or more (75°F or more) : 15 minutes or more**

6. Install from roof side molding rear end to front end in this order after temporarily holding.

#### **CAUTION:**

- Use double-faced adhesive tape after hardening for clips.
- Securely insert molding rear end cap onto roof rear end cutout (installation standard).
- When installing roof side molding of windshield portion, check that molding fastener is securely inserted and then press in.
- Never wash the vehicle within 24 hours so as to keep adhesive.



# FRONT PILLAR FINISHER

< REMOVAL AND INSTALLATION >

## FRONT PILLAR FINISHER

Exploded View

INFOID:000000004249877

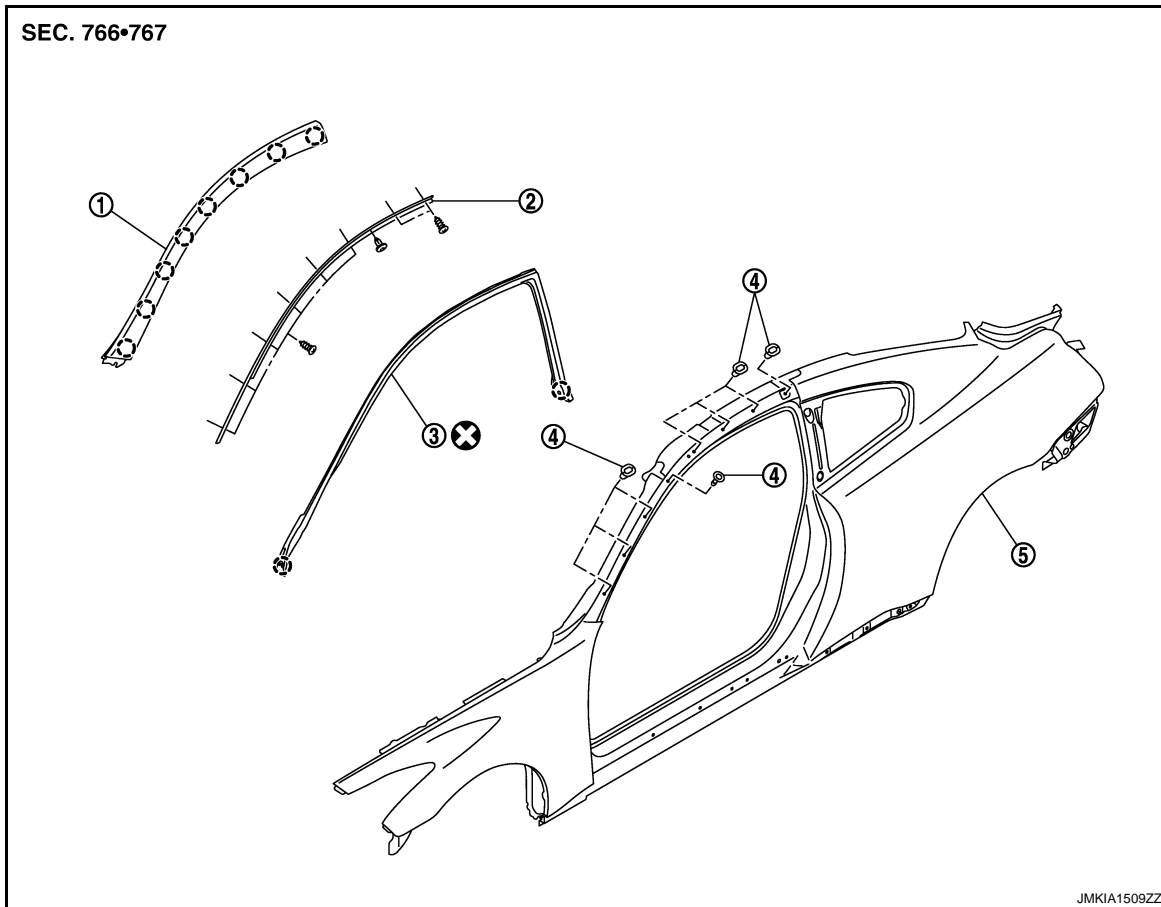

- |                          |                                     |                            |
|--------------------------|-------------------------------------|----------------------------|
| 1. Front pillar finisher | 2. Body side weather-strip retainer | 3. Body side weather-strip |
| 4. Grommet               | 5. Body side outer                  |                            |

○ : Clip

Refer to [GI-4. "Components"](#) for symbols in the figure.

## Removal and Installation

INFOID:000000004249878

### Removal

1. Remove clip and double faced adhesive tapes of body side weather-strip.
2. Remove body side weather-strip.
3. Remove body side weather-strip retainer (1) mounting screws (A) and clip (B), and then remove body side weather-strip retainer (1).

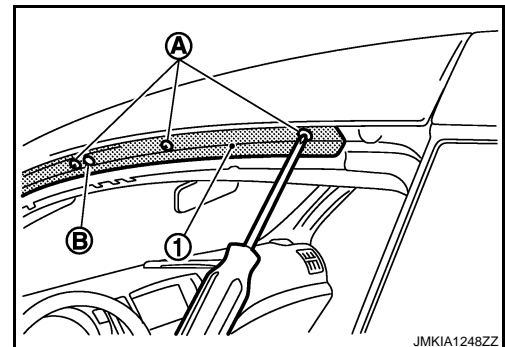

A  
B  
C  
D  
E  
F  
G  
H  
I  
J

EXT

L

M

N

O

P

## FRONT PILLAR FINISHER

### < REMOVAL AND INSTALLATION >

4. Remove front pillar finisher (1) fixing clips with remover tool (A).

 : Clip

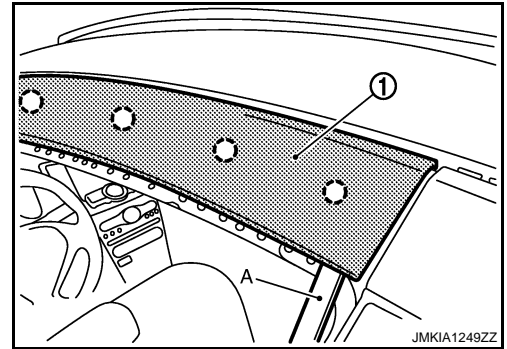

5. Remove front pillar finisher.

#### Installation

Install in the reverse order of removal.

# DOOR OUTSIDE MOLDING

< REMOVAL AND INSTALLATION >

## DOOR OUTSIDE MOLDING

Exploded View

INFOID:000000004249879

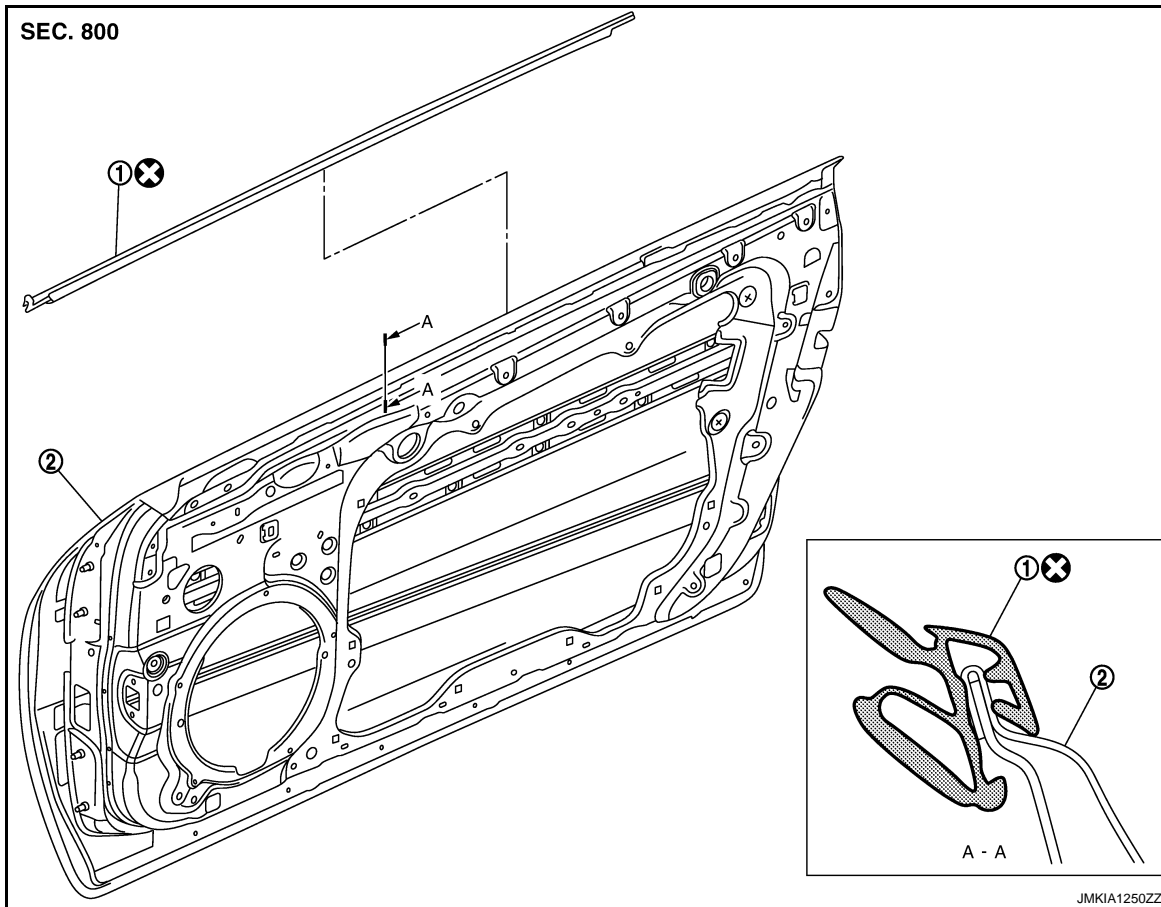

1. Door outside molding                      2. Door panel assembly

Refer to [GI-4, "Components"](#) for symbols in the figure.

## Removal and Installation

INFOID:000000004249880

### REMOVAL

1. Remove door finisher. Refer to [INT-11, "Removal and Installation"](#).
2. Remove door mirror assembly. Refer to [MIR-18, "DOOR MIRROR ASSEMBLY : Removal and Installation"](#).
3. Twists and pull up to upper side, and then remove front door outside molding (1).

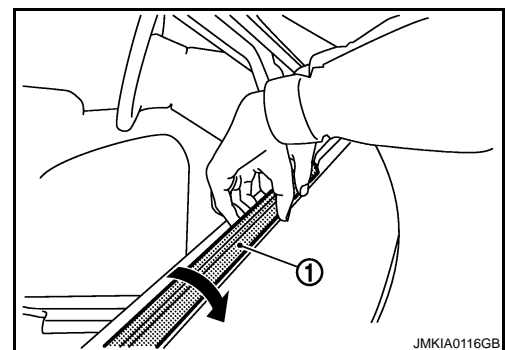

### INSTALLATION

Install in the reverse order of removal.

A  
B  
C  
D  
E  
F  
G  
H  
I  
J

EXT

L  
M  
N  
O  
P

# DOOR PARTING SEAL

< REMOVAL AND INSTALLATION >

## DOOR PARTING SEAL

Exploded View

INFOID:000000004249881

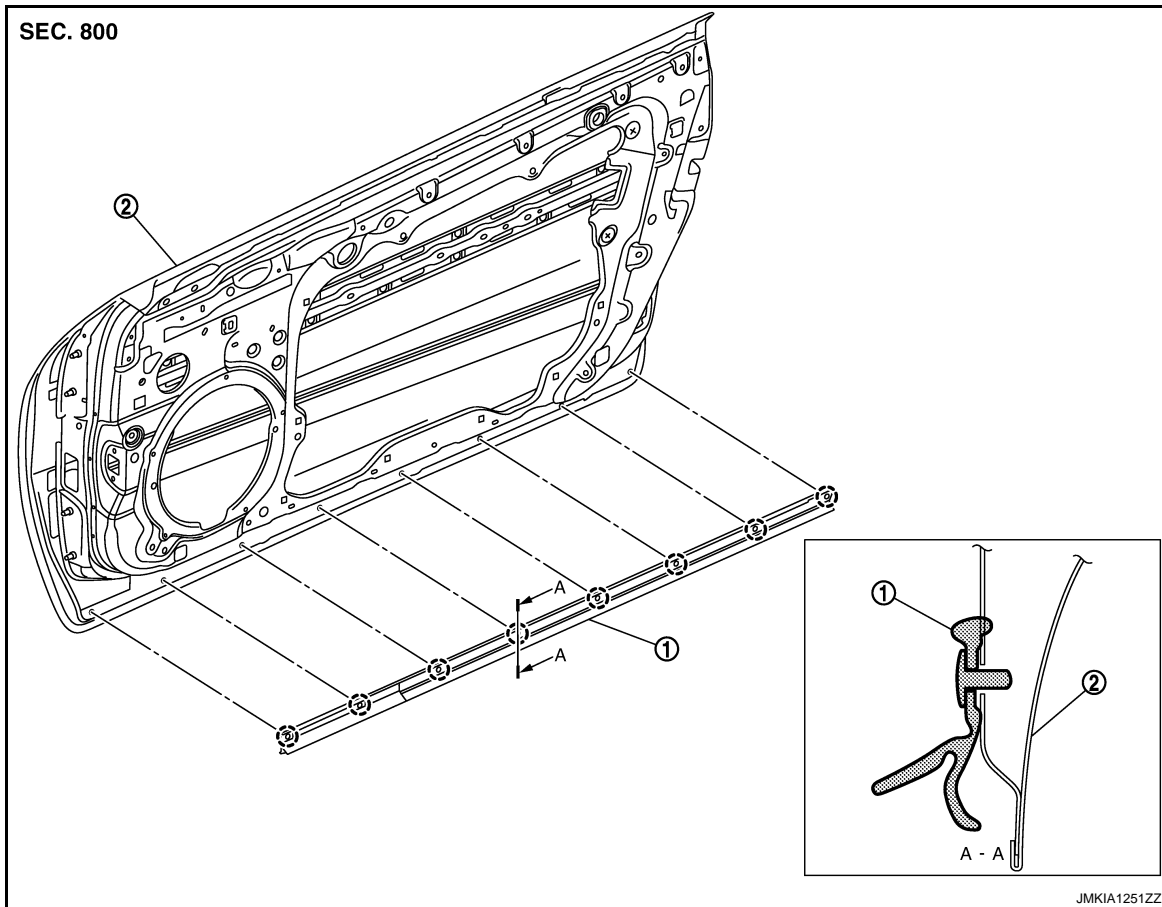

1. Door parting seal

2. Door panel assembly

( ) : Clip

## Removal and Installation

INFOID:000000004249882

### REMOVAL

1. Fully open door.
2. Remove door parting seal mounting plastic clips with remover tool.
3. Remove door parting seal.

### INSTALLATION

Install in the reverse order of removal.

# TRUNK LID FINISHER

< REMOVAL AND INSTALLATION >

## TRUNK LID FINISHER

### TRUNK LID OUTER FINISHER

#### TRUNK LID OUTER FINISHER : Exploded View

INFOID:000000004249883

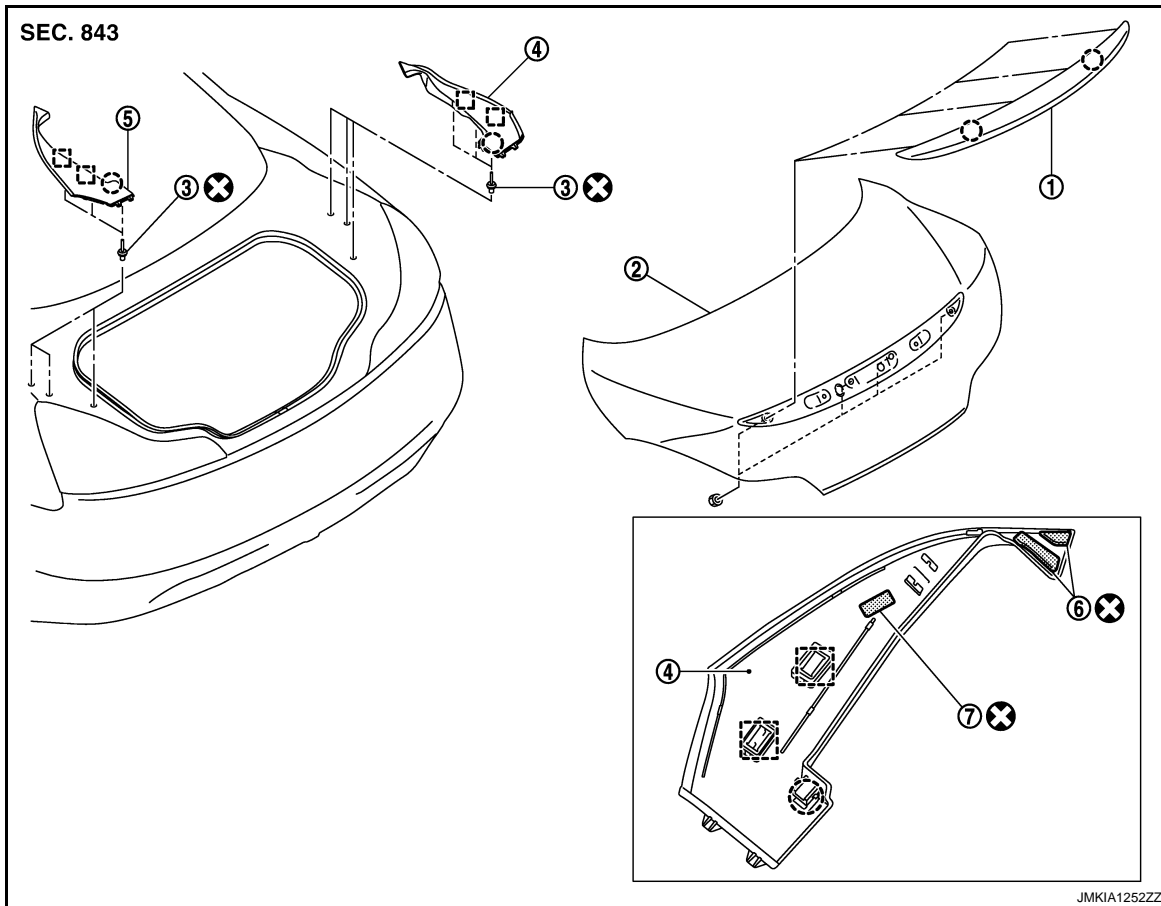

- |   |                             |   |
|---|-----------------------------|---|
| 1. Trunk lid finisher outer                             | 2. Trunk lid panel assembly | 3. Rivet  |
| 4. Trunk drip cover RH                                  | 5. Trunk drip cover LH      | 6. Double-faced adhesive tape<br>[t: 4.0 mm (0.157 in)] |
| 7. Double-faced adhesive tape<br>[t: 2.5 mm (0.098 in)] |                             |   |

- : Clip  
□ : Metal clip

Refer to [GI-4, "Components"](#) for symbols in the figure.

#### TRUNK LID OUTER FINISHER : Removal and Installation

INFOID:000000004249884

##### REMOVAL

1. Fully open trunk lid.
2. Remove trunk lid trim. Refer to [INT-29, "Removal and Installation"](#).

## TRUNK LID FINISHER

### < REMOVAL AND INSTALLATION >

3. Remove trunk lid finisher outer mounting nuts (A).

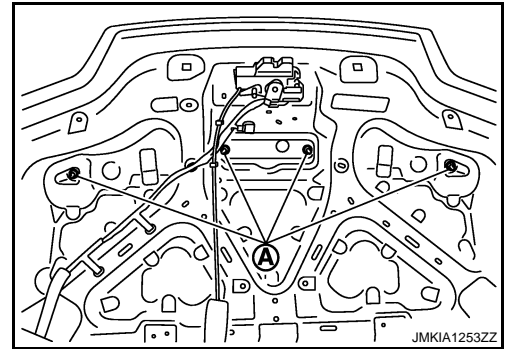

4. Apply protection tape (A) around outer circumference of trunk lid finisher outer (1).
5. Remove trunk lid finisher outer, using remover tool (B).

 : Clip

**CAUTION:**  
Be careful not to damage the body.

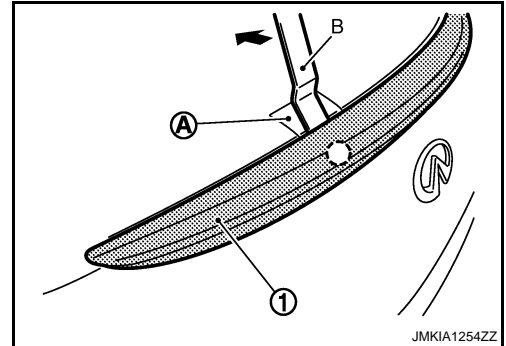

### INSTALLATION

Install in the reverse order of removal.

#### **CAUTION:**

- Install after cleaning adhesive parts of body side and back of finisher outer.
- When installing door finisher, check that clips are securely fitted in panel holes on body, and then press them in.

### TRUNK DRIP COVER

# TRUNK LID FINISHER

< REMOVAL AND INSTALLATION >

## TRUNK DRIP COVER : Exploded View

INFOID:000000004249885

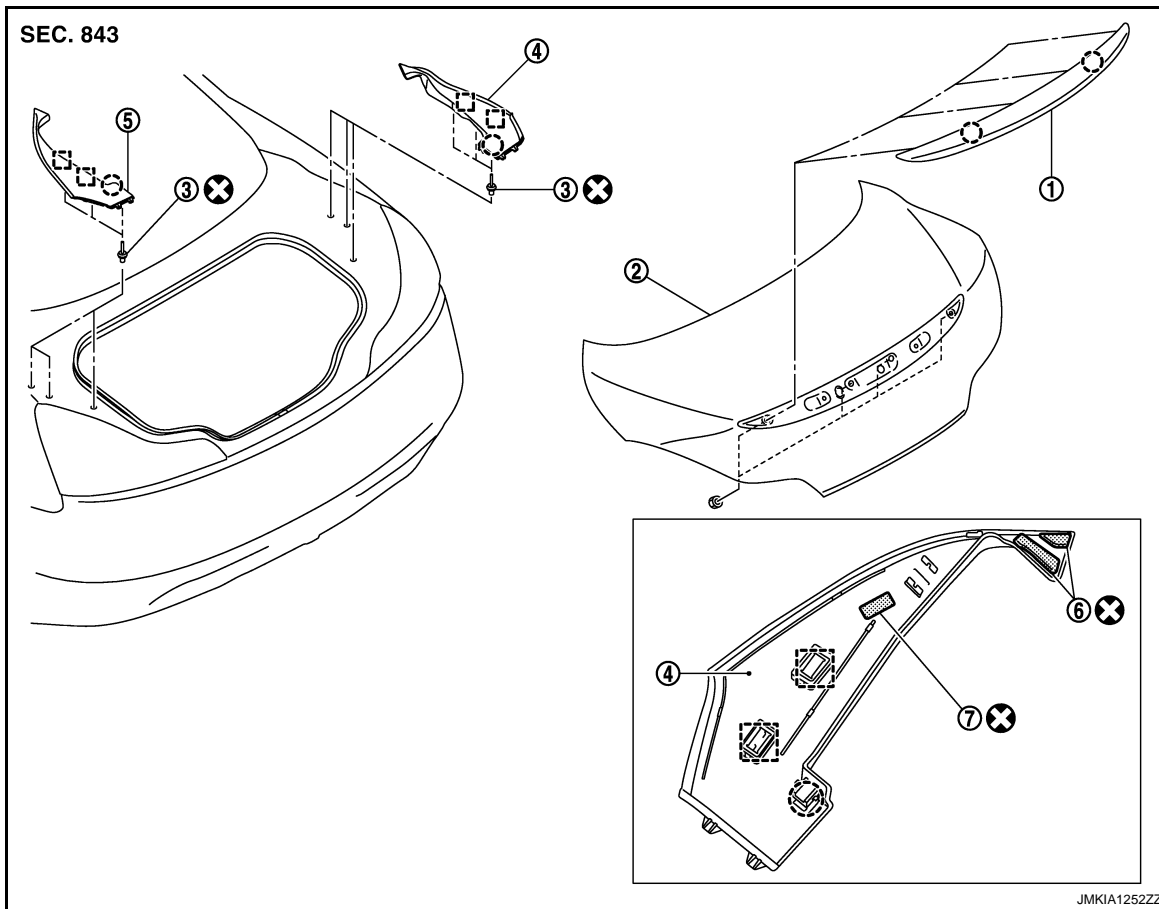

- |   |                             |   |
|---|-----------------------------|---|
| 1. Trunk lid finisher outer                             | 2. Trunk lid panel assembly | 3. Rivet  |
| 4. Trunk drip cover RH                                  | 5. Trunk drip cover LH      | 6. Double-faced adhesive tape<br>[t: 4.0 mm (0.157 in)] |
| 7. Double-faced adhesive tape<br>[t: 2.5 mm (0.098 in)] |                             |   |

○ : Clip

□ : Metal clip

Refer to [GI-4. "Components"](#) for symbols in the figure.

## TRUNK DRIP COVER : Removal and Installation

INFOID:000000004249886

### REMOVAL

1. Fully open trunk lid.
2. Remove double-faced adhesive tape (A) of trunk drip cover (1) with remover tool (B).

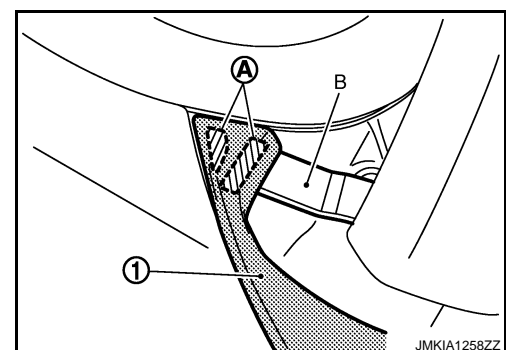

A  
B  
C  
D  
E  
F  
G  
H  
I  
J  
EXT  
L  
M  
N  
O  
P

# TRUNK LID FINISHER

## < REMOVAL AND INSTALLATION >

3. Disengage trunk drip cover (1) fixing clip using remover tool (A).

 : Clip

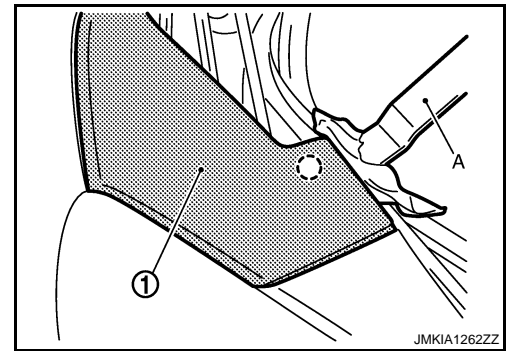

4. Disengage trunk drip cover (1) fixing metal clip using remover tool (A).

 : Metal clip

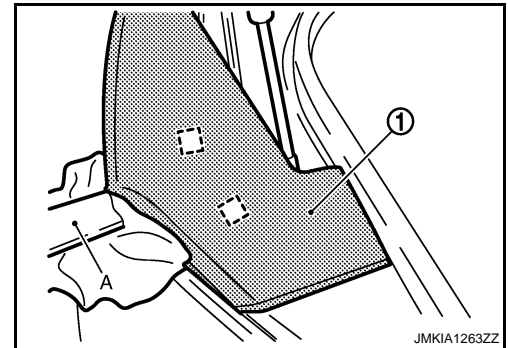

5. Slide forward then remove drip cover (1).

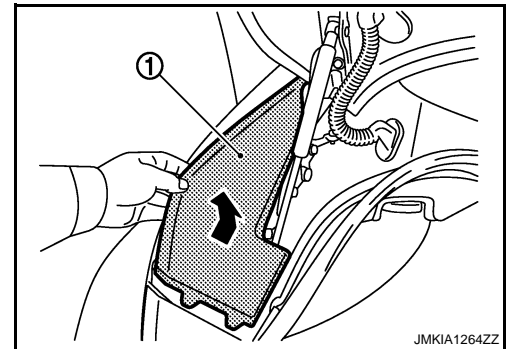

## INSTALLATION

Install in the reverse order of removal.

### **CAUTION:**

- Double-faced adhesive tape is not reusable, always use new double-faced adhesive tape.
- Never wash vehicle with in 24 hours after installation.



# REAR SPOILER

< REMOVAL AND INSTALLATION >

## REAR SPOILER

Exploded View

INFOID:000000004249887

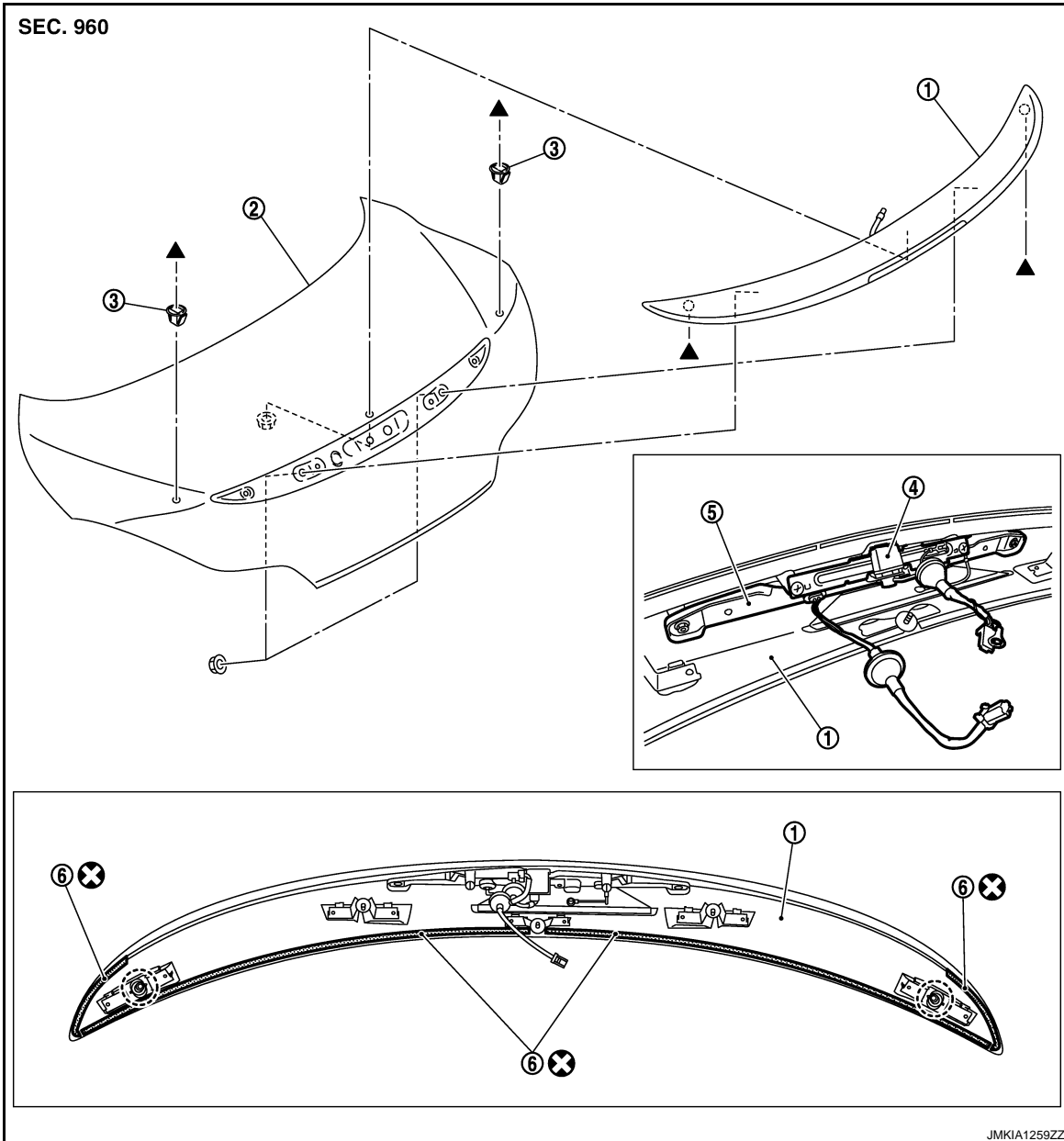

- |                              |                             |  |
|------------------------------|-----------------------------|--|
| 1. Rear spoiler assembly     | 2. Trunk lid panel assembly | 3. Grommet   |
| 4. Rear view camera assembly | 5. High-mounted stop lamp   | 6. Double-faced adhesive tape<br>[t: 2.0mm (0.079 in)] |

○ : Clip

Refer to [GI-4, "Components"](#) for symbols in the figure.

## Removal and Installation

INFOID:000000004249888

### REMOVAL

1. Remove trunk lid trim. Refer to [INT-29, "Removal and Installation"](#).

A  
B  
C  
D  
E  
F  
G  
H  
I  
J  
EXT  
L  
M  
N  
O  
P

## REAR SPOILER

### < REMOVAL AND INSTALLATION >

2. Disconnect harness connector (A) of high-mounted stop lamp.
3. Disconnect harness connector (B) of rear view camera.
4. Remove bolt (C).

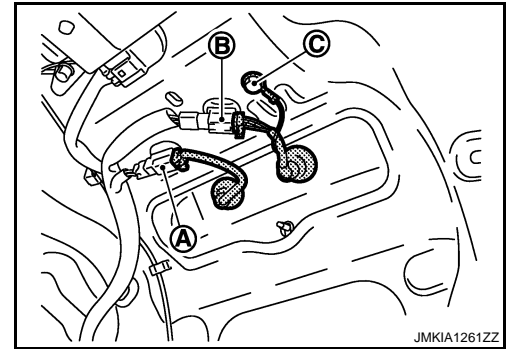

5. Remove rear spoiler mounting nuts (A).

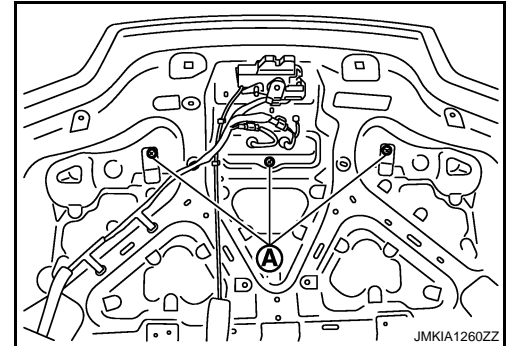

6. Release rear spoiler connection between trunk lid panel and rear spoiler, using a remover tool, and take off double-faced adhesive tape.
7. Disengage rear spoiler mounting clip, and then disconnect grommets of high-mounted stop lamp harness and rear view camera harness.
8. Remove rear spoiler.
9. Remove following parts after removing rear spoiler.
  - High-mounted stop lamp. Refer to [EXL-205, "WITH REAR SPOILER : Removal and Installation"](#).
  - Rear view camera. Refer to [AV-638, "Removal and Installation"](#).
  - Rear spoiler clip and grommet.

### INSTALLATION

Install in the reverse order of removal.

#### **CAUTION:**

- **Be careful not to damage the body.**
- **Never let air between contact surfaces when installing.**
- **Never wash vehicle within 24 hours after installation.**